

EU

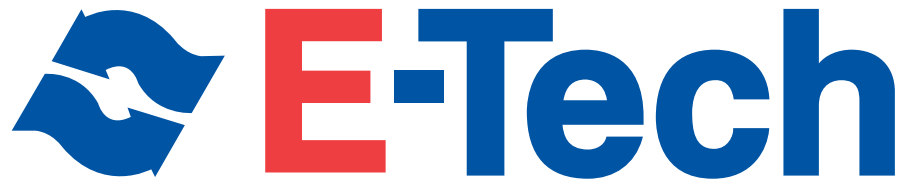

SUBMERSIBLE PUMPS, MOTORS AND ACCESSORIES

50Hz



INDEX

VS Series Stainless Steel Submersible Pumps for 6" deep wells and larger	4	Submersible Motors Product	
General Product Curves 6"	5	4" Encapsulated Motors - 4" Super Stainless 3 Phase	56
Material Table 6"	5	6" Encapsulated Motors	58
<hr/>		6" Rewindable Motors	60
Table of Hydraulic Performance		8" Encapsulated Motors	62
VS 14 MEI \geq 0,10	6	8" Rewindable Motors	64
VS 19 MEI \geq 0,10	7	<hr/>	
VS 30 MEI \geq 0,40	8	Accessories	
VS 46 MEI \geq 0,40	9	Motor Control - Submonitor Motor Protection	66
VS 65 MEI \geq 0,40	10	Motor Control - SubStartSC® Single phase Submersible Motor Starter	67
<hr/>		Termination Kit 4"	68
Technical Data and Performance Curves 50Hz		Double Plug Lead for Termination Kit	68
VS 14	14	Corrosion Protection 4"	68
VS 14 High Pressure	18	Motor Filling Kit	68
VS 19	20	6" Permanent Star Plug	68
VS 19 High Pressure	24	Surge Arrestor	69
VS 30	26	PT100 for 6" and 8" Encapsulated Motors	69
VS 30 High Pressure	28	PT100 Rewindable Motors	69
VS 46	30	<hr/>	
VS 46 High Pressure	32		
VS 65	34		
VS 65 High Pressure	36		
<hr/>			
Section and list of main components			
VS 14 - VS 19	38		
VS 30 - VS 46 - VS 65	39		
<hr/>			
Appendix A			
Motor Adapter VS 14 - VS 19	40		
Motor Adapter VS 30 - VS 46 - VS 65	41		
<hr/>			
VS Series Stainless Steel Submersible Pumps for 8" deep wells and larger	43		
General Product Curves 8"	45		
Material Table 8"	45		
<hr/>			
Table of Hydraulic Performance			
VS 78	48		
VS 97	49		
<hr/>			
Technical Data and Performance Curves 50Hz			
VS 78	50		
VS 97	51		
<hr/>			
Section and list of main components			
VS 78 - VS 97	52		
<hr/>			
Appendix B			
Motor Adapter VS 78 - VS 97	53		

VS Series Stainless Steel Submersible Pumps for 6" deep wells and larger

Characteristics and Hydraulic Performances

50 Hz

APPLICATIONS

- Municipal water works
- Water distribution and pressure boosting
- Irrigation and sprinkler systems, water treatment plants, filtration and reverse osmosis
- Industrial cooling and processing
- Mining industry, drainage and dewatering
- Fountains
- Fire-fighting equipment
- General industry

FEATURES

- Fabricated stainless steel impellers and diffusers for corrosion resistance
- Heavy duty stainless steel structure to assure permanent alignment of all the components in order to increase run time and trouble-free operation
- PTFE floating neck ring, ceramic guide journal sleeve (tungsten-carbide on request) and Nitrile rubber fluted bearing to ensure durability against wear for long-lasting constant performances and product reliability
- Compact, reliable and suited to operate in horizontal position
- Built-in check valve to protect the pump against water hammer risk
- External stainless steel sleeve to improve stiffness and assure permanent alignment of all the components
- Radial models with double reinforcement rings and mix-flow models longer than 3 mt are equipped with tungsten-carbide (widia) upper journal sleeve and with an intermediate tungsten-carbide (widia) journal sleeve plus special intermediate split cone nut
- The hydraulic design is such to enhance the overall efficiency thus reducing energy consumption and making the pumping systems more cost effective

SPECIFICATIONS

- Capacities up to 80 m³/h at 50Hz
- 70 Bar (700 m) at 50Hz
- Maximum allowable amount of sand 100 gr/m³
- Water temperature range: from -5° C to 60°C
- Rotation: counter clockwise when looking into the discharge
- Motor adapter in compliance with NEMA standard
- Pump can work continuously in vertical or horizontal position
- Motors: see section Submersible Motors Product Overview

AVAILABLE OPTIONS

- 316 Stainless steel (N) version (DIN/EN 1.4401)
- Double cable guard
- Rp 2" and Rp 3" discharge heads for VS 14 and VS 19
- Rp 4" discharge head
- 4" motor adapter
- 8" motor adapter
- Tungsten-carbide guide journal sleeve
- High temperature version (up to 90° C)

PUMP IDENTIFICATION CODE

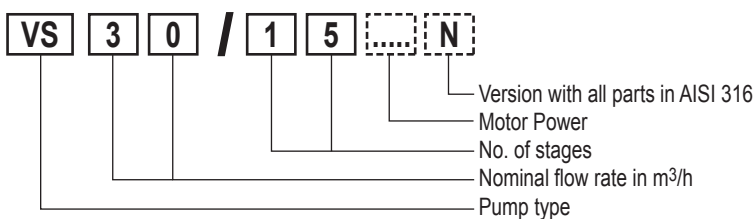

00117023 07/2010

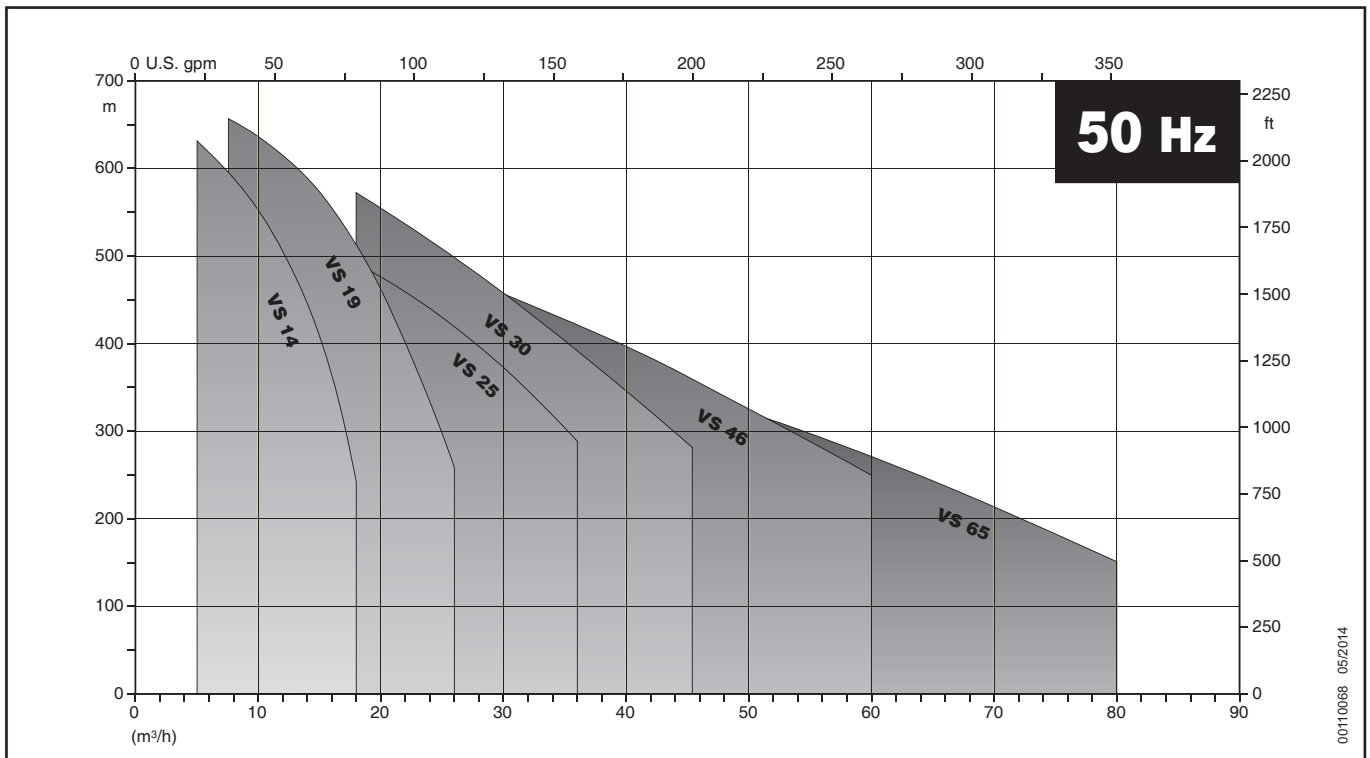

00110068 05/2014

MATERIAL IN CONTACT WITH THE LIQUID

Pos.	PARTS DESCRIPTIONS	Type	MATERIAL			
			Standard version		N version	
			AISI	DIN / EN	AISI	DIN / EN
10.00	Discharge head	Stainless steel	304	1.4301	316	1.4401
10.01 / 04 / 05	Valve	Stainless steel	316	1.4401	316	1.4401
10.02	Sealing O-ring	Nitrile rubber (NBR)	-	-	-	-
10.03	Outer case locking nuts	Stainless steel	316	1.4401	316	1.4401
20.00	Outer case	Stainless steel	304	1.4301	316	1.4401
20.01	Suction strainer	Stainless steel	316	1.4401	316	1.4401
20.02	Cable guard	Stainless steel	316	1.4401	316	1.4401
20.03	Initial spacer	Stainless steel	304	1.4301	316	1.4401
20.04	Flange and screws	Stainless steel	304	1.4301	316	1.4401
20.05	Motor adapter	Stainless steel	304	1.4301	316	1.4401
30.00	Pump shaft	Stainless steel	431	1.4057	316/329	1.4401/1.4460
30.01	Coupling	Stainless steel	431/329	1.4057/1.4460	316/329	1.4401/1.4460
30.02 / 03	Upper / Lower up-thrust washer	Stainless steel	316	1.4401	316	1.4401
30.04	Upper journal sleeve	Stainless steel with ceramic coating	329	1.4460	329	1.4460
30.05	Screw and washer	Stainless steel	316	1.4401	316	1.4401
30.06	Up-thrust ring	PTFE + Graphite	-	-	-	-
30.07 / 08	Lower / Upper spacer	Stainless steel	316	1.4401	316	1.4401
40.00	Diffuser	Stainless steel	304	1.4301	316	1.4401
40.01	Secondary bearing bush	Nitrile rubber (NBR)	-	-	-	-
40.02	Floating neck ring	PTFE	-	-	-	-
40.03	Flange clamping neck ring	Stainless steel	304	1.4301	316	1.4401
40.04	Bearing bush	Nitrile rubber (NBR)	-	-	-	-
40.05	Last - int. diffuser / Upper bearing guide	Stainless steel	316	1.4401	316	1.4401
40.06 / 07 / 08	First / Last diffuser	Stainless steel	316	1.4401	316	1.4401
50.00 / 05	Impeller / Wear ring	Stainless steel	304	1.4301	316	1.4401
50.01	Split cone / Impeller spacer	Stainless steel	316	1.4401	316	1.4401
50.02 / 03	Split cone nut / Intermediate cone nut	Stainless steel	316	1.4401	316	1.4401
50.04	Up-thrust split cone nut	Stainless steel	316	1.4401	316	1.4401
50.06	Intermediate impeller with screw	Stainless steel	304	1.4301	316	1.4401

VS14

TABLE OF HYDRAULIC PERFORMANCES AT 50Hz

PUMP TYPE	RATED POWER		Q = DELIVERY										
	kW	HP	m ³ /h	0	6	8	10	12	15	18	21	24	27
			l/min	0	100	133	167	200	250	300	350	400	450
H = TOTAL HEAD METERS COLUMN OF WATER [m]													
VS 14/5	4	5,5		56,1	50,7	48,4	45,4	41,4	31,3	18,6			
VS 14/6	4	5,5		67,3	60,8	58,1	54,5	49,7	37,5	22,3			
VS 14/7	4	5,5		78,5	71,0	67,8	63,6	58,0	43,8	26,0			
VS 14/8	4	5,5		89,7	81,1	77,5	72,7	66,3	50,0	29,7			
VS 14/9	5,5	7,5		100,9	91,2	87,2	81,8	74,6	56,3	33,4			
VS 14/10	5,5	7,5		112,1	101,4	96,9	90,9	82,9	62,5	37,1			
VS 14/11	5,5	7,5		123,3	111,5	106,6	100,0	91,2	68,8	40,8			
VS 14/12	5,5	7,5		134,6	121,7	116,3	109,1	99,5	75,0	44,6			
VS 14/13	5,5	7,5		145,8	131,8	125,9	118,1	107,7	81,3	48,3			
VS 14/14	7,5	10		157,0	141,9	135,6	127,2	116,0	87,5	52,0			
VS 14/15	7,5	10		168,2	152,1	145,3	136,3	124,3	93,8	55,7			
VS 14/16	7,5	10		179,4	162,2	155,0	145,4	132,6	100,0	59,4			
VS 14/17	7,5	10		190,6	172,3	164,7	154,5	140,9	106,3	63,1			
VS 14/18	9,3	12,5		201,8	182,5	174,4	163,6	149,2	112,5	66,8			
VS 14/19	9,3	12,5		213,0	192,6	184,1	172,7	157,5	118,8	70,5			
VS 14/20	9,3	12,5		224,3	202,8	193,8	181,8	165,8	125,0	74,3			
VS 14/21	9,3	12,5		235,5	212,9	203,4	190,8	174,0	131,3	78,0			
VS 14/22	9,3	12,5		246,7	223,0	213,1	199,9	182,3	137,5	81,7			
VS 14/23	11	15		257,9	233,2	222,8	209,0	190,6	143,8	85,4			
VS 14/24	11	15		269,1	243,3	232,5	218,1	198,9	150,0	89,1			
VS 14/25	11	15		280,3	253,4	242,2	227,2	207,2	156,3	92,8			
VS 14/26	11	15		291,5	263,6	251,9	236,3	215,5	162,5	96,5			
VS 14/27	15	20		302,7	273,7	261,6	245,4	223,8	168,8	100,2			
VS 14/28	15	20		314,0	283,9	271,3	254,5	232,1	175,0	104,0			
VS 14/29	15	20		325,2	294,0	280,9	263,5	240,3	181,3	107,7			
VS 14/30	15	20		336,4	304,1	290,6	272,6	248,6	187,5	111,4			
VS 14/31	15	20		347,6	314,3	300,3	281,7	256,9	193,8	115,1			
VS 14/32	15	20		358,8	324,4	310,0	290,8	265,2	200,0	118,8			
VS 14/33	15	20		370,0	334,5	319,7	299,9	273,5	206,3	122,5			
VS 14/34	15	20		381,2	344,7	329,4	309,0	281,8	212,5	126,2			
VS 14/35	15	20		392,4	354,8	339,1	318,1	290,1	218,8	129,9			
VS 14/36	15	20		403,7	365,0	348,8	327,2	298,4	225,0	133,7			
VS 14/37	18,5	25		414,9	375,1	358,4	336,2	306,6	231,3	137,4			
VS 14/38	18,5	25		426,1	385,2	368,1	345,3	314,9	237,5	141,1			
VS 14/39	18,5	25		437,3	395,4	377,8	354,4	323,2	243,8	144,8			
VS 14/40	18,5	25		448,5	405,5	387,5	363,5	331,5	250,0	148,5			
VS 14/41	18,5	25		459,7	415,6	397,2	372,6	339,8	256,3	152,2			
VS 14/42	18,5	25		470,9	425,8	406,9	381,7	348,1	262,5	155,9			
VS 14/43	18,5	25		482,1	435,9	416,6	390,8	356,4	268,8	159,6			
VS 14/44	18,5	25		493,4	446,1	426,3	399,9	364,7	275,0	163,4			
VS 14/45	22	30		504,6	456,2	435,9	408,9	372,9	281,3	167,1			
VS 14/46	22	30		515,8	466,3	445,6	418,0	381,2	287,5	170,8			
VS 14/47	22	30		527,0	476,5	455,3	427,1	389,5	293,8	174,5			
VS 14/48	22	30		538,2	486,6	465,0	436,2	397,8	300,0	178,2			
VS 14/49	22	30		549,4	496,7	474,7	445,3	406,1	306,3	181,9			
VS 14/50	22	30		560,6	506,9	484,4	454,4	414,4	312,5	185,6			
VS 14/51	22	30		571,8	517,0	494,1	463,5	422,7	318,8	189,3			
VS 14/52	22	30		583,1	527,2	503,8	472,6	431,0	325,0	193,1			
VS 14/53	30	40		594,3	537,3	513,4	481,6	439,2	331,3	196,8			
VS 14/54	30	40		605,5	547,4	523,1	490,7	447,5	337,5	200,5			
VS 14/55	30	40		616,7	557,6	532,8	499,8	455,8	343,8	204,2			
VS 14/56	30	40		627,9	567,7	542,5	508,9	464,1	350,0	207,9			
VS 14/57	30	40		639,1	577,8	552,2	518,0	472,4	356,3	211,6			
VS 14/58	30	40		650,3	588,0	561,9	527,1	480,7	362,5	215,3			
VS 14/59	30	40		661,5	598,1	571,6	536,2	489,0	368,8	219,0			
VS 14/60	30	40		672,8	608,3	581,3	545,3	497,3	375,0	222,8			
VS 14/61	30	40		684,0	618,4	590,9	554,3	505,5	381,3	226,5			

VS19

TABLE OF HYDRAULIC PERFORMANCES AT 50Hz

PUMP TYPE	RATED POWER		Q = DELIVERY										
	kW	HP	m ³ /h	0	6	8	10	12	15	18	21	24	27
			l/min	0	100	133	167	200	250	300	350	400	450
H = TOTAL HEAD METERS COLUMN OF WATER [m]													
VS 19/6	4	5,5	70,0			66,4	64,0	62,0	57,6	51,6	43,2	32,9	20,5
VS 19/7	5,5	7,5	81,7			77,5	74,7	72,3	67,2	60,2	50,4	38,4	23,9
VS 19/8	5,5	7,5	93,3			88,5	85,3	82,7	76,8	68,8	57,6	43,9	27,4
VS 19/9	5,5	7,5	105,0			99,6	96,0	93,0	86,4	77,4	64,8	49,4	30,8
VS 19/10	7,5	10	116,7			110,7	106,7	103,3	96,0	86,0	72,0	54,9	34,2
VS 19/11	7,5	10	128,3			121,7	117,3	113,7	105,6	94,6	79,2	60,4	37,6
VS 19/12	7,5	10	140,0			132,8	128,0	124,0	115,2	103,2	86,4	65,8	41,0
VS 19/13	9,3	12,5	151,7			143,9	138,7	134,3	124,8	111,8	93,6	71,3	44,5
VS 19/14	9,3	12,5	163,3			154,9	149,3	144,7	134,4	120,4	100,8	76,8	47,9
VS 19/15	9,3	12,5	175			166	160	155	144	129	108	82,3	51,3
VS 19/16	11	15	186,7			177,1	170,7	165,3	153,6	137,6	115,2	87,8	54,7
VS 19/17	11	15	198,3			188,1	181,3	175,7	163,2	146,2	122,4	93,3	58,1
VS 19/18	11	15	210,0			199,2	192,0	186,0	172,8	154,8	129,6	98,8	61,6
VS 19/19	15	20	221,7			210,3	202,7	196,3	182,4	163,4	136,8	104,2	65,0
VS 19/20	15	20	233,3			221,3	213,3	206,7	192,0	172,0	144,0	109,7	68,4
VS 19/21	15	20	245,0			232,4	224,0	217,0	201,6	180,6	151,2	115,2	71,8
VS 19/22	15	20	256,7			243,5	234,7	227,3	211,2	189,2	158,4	120,7	75,2
VS 19/23	15	20	268,3			254,5	245,3	237,7	220,8	197,8	165,6	126,2	78,7
VS 19/24	15	20	280,0			265,6	256,0	248,0	230,4	206,4	172,8	131,7	82,1
VS 19/25	18,5	25	291,7			276,7	266,7	258,3	240,0	215,0	180,0	137,2	85,5
VS 19/26	18,5	25	303,3			287,7	277,3	268,7	249,6	223,6	187,2	142,7	88,9
VS 19/27	18,5	25	315,0			298,8	288,0	279,0	259,2	232,2	194,4	148,1	92,3
VS 19/28	18,5	25	326,7			309,9	298,7	289,3	268,8	240,8	201,6	153,6	95,8
VS 19/29	18,5	25	338,3			320,9	309,3	299,7	278,4	249,4	208,8	159,1	99,2
VS 19/30	18,5	25	350,0			332,0	320,0	310,0	288,0	258,0	216,0	164,6	102,6
VS 19/31	22	30	361,7			343,1	330,7	320,3	297,6	266,6	223,2	170,1	106,0
VS 19/32	22	30	373,3			354,1	341,3	330,7	307,2	275,2	230,4	175,6	109,4
VS 19/33	22	30	385,0			365,2	352,0	341,0	316,8	283,8	237,6	181,1	112,9
VS 19/34	22	30	396,7			376,3	362,7	351,3	326,4	292,4	244,8	186,5	116,3
VS 19/35	22	30	408,3			387,3	373,3	361,7	336,0	301,0	252,0	192,0	119,7
VS 19/36	22	30	420,0			398,4	384,0	372,0	345,6	309,6	259,2	197,5	123,1
VS 19/37	30	40	431,7			409,5	394,7	382,3	355,2	318,2	266,4	203,0	126,5
VS 19/38	30	40	443,3			420,5	405,3	392,7	364,8	326,8	273,6	208,5	130,0
VS 19/39	30	40	455,0			431,6	416,0	403,0	374,4	335,4	280,8	214,0	133,4
VS 19/40	30	40	466,7			442,7	426,7	413,3	384,0	344,0	288,0	219,5	136,8
VS 19/41	30	40	478,3			453,7	437,3	423,7	393,6	352,6	295,2	225,0	140,2
VS 19/42	30	40	490,0			464,8	448,0	434,0	403,2	361,2	302,4	230,4	143,6
VS 19/43	30	40	501,7			475,9	458,7	444,3	412,8	369,8	309,6	235,9	147,1
VS 19/44	30	40	513,3			486,9	469,3	454,7	422,4	378,4	316,8	241,4	150,5
VS 19/45	30	40	525,0			498,0	480,0	465,0	432,0	387,0	324,0	246,9	153,9
VS 19/46	30	40	536,7			509,1	490,7	475,3	441,6	395,6	331,2	252,4	157,3
VS 19/47	30	40	548,3			520,1	501,3	485,7	451,2	404,2	338,4	257,9	160,7
VS 19/48	30	40	560,0			531,2	512,0	496,0	460,8	412,8	345,6	263,4	164,2
VS 19/49	30	40	571,7			542,3	522,7	506,3	470,4	421,4	352,8	268,8	167,6
VS 19/50	37	50	583,3			553,3	533,3	516,7	480,0	430,0	360,0	274,3	171,0
VS 19/51	37	50	595,0			564,4	544,0	527,0	489,6	438,6	367,2	279,8	174,4
VS 19/52	37	50	606,7			575,5	554,7	537,3	499,2	447,2	374,4	285,3	177,8
VS 19/53	37	50	618,3			586,5	565,3	547,7	508,8	455,8	381,6	290,8	181,3
VS 19/54	37	50	630,0			597,6	576,0	558,0	518,4	464,4	388,8	296,3	184,7
VS 19/55	37	50	641,7			608,7	586,7	568,3	528,0	473,0	396,0	301,8	188,1
VS 19/56	37	50	653,3			619,7	597,3	578,7	537,6	481,6	403,2	307,3	191,5
VS 19/57	37	50	665,0			630,8	608,0	589,0	547,2	490,2	410,4	312,7	194,9
VS 19/58	37	50	676,7			641,9	618,7	599,3	556,8	498,8	417,6	318,2	198,4
VS 19/59	37	50	688,3			652,9	629,3	609,7	566,4	507,4	424,8	323,7	201,8
VS 19/60	37	50	700,0			664,0	640,0	620,0	576,0	516,0	432,0	329,2	205,2

VS30

TABLE OF HYDRAULIC PERFORMANCES AT 50Hz

PUMP TYPE	RATED POWER		Q = DELIVERY																	
	kW	HP	m ³ /h	0	5	10	15	20	25	30	35	40	45	50	55	60	65	70	75	80
			l/min	0	83,5	166,5	250	333,5	416,5	500	583,5	666,5	750	833,5	916,5	1000	1083,5	1166,5	1250	1333,5
H = TOTAL HEAD METERS COLUMN OF WATER [m]																				
VS 30/3	3,7	5	46,3				38,9	36	33,3	30,2	26,7	21,7	15,3							
VS 30/4	5,5	7,5	62,5				52,6	48,8	45,2	41,1	36,5	30	21,4							
VS 30/5	7,5	10	78,6				66,2	61,5	56,9	51,8	46,1	38	27,4							
VS 30/6	7,5	10	93,1				78,4	72,6	67,1	61	54	44,1	31,2							
VS 30/7	9,3	12,5	110				92,6	86	79,7	72,6	64,6	53,3	38,4							
VS 30/8	11	15	125,5				105,7	98,1	90,9	82,7	73,6	60,5	43,5							
VS 30/9	11	15	140,1				117,9	109,3	101,1	91,8	81,4	66,6	47,3							
VS 30/10	15	20	158,2				133,3	123,8	114,9	104,7	93,5	77,3	56,1							
VS 30/11	15	20	173				145,7	135,3	125,4	114,1	101,7	83,8	60,4							
VS 30/12	15	20	187,7				158	146,6	135,7	123,4	109,6	90	64,4							
VS 30/13	18,5	25	205,2				172,9	160,6	148,9	135,7	121,1	100	72,4							
VS 30/14	18,5	25	220				185,3	172,1	159,4	145,1	129,2	106,5	76,7							
VS 30/15	22	30	237				199,7	185,5	172,1	156,8	140	115,7	84							
VS 30/16	22	30	251,9				212,2	197,1	182,6	166,3	148,3	122,3	88,3							
VS 30/17	22	30	266,7				224,5	208,4	193	175,7	156,4	128,7	92,5							
VS 30/18	22	30	281,3				236,8	219,7	203,3	185	164,3	134,9	96,5							
VS 30/19	30	40	302,1				254,7	236,8	219,9	200,7	179,7	149,2	109,1							
VS 30/20	30	40	317,3				267,4	248,6	230,7	210,5	188,2	156	113,8							
VS 30/21	30	40	332,3				280	260,2	241,5	220,1	196,7	162,8	118,3							
VS 30/22	30	40	347,3				292,6	271,8	252,1	229,7	205	169,4	122,7							
VS 30/23	30	40	362,2				305,1	283,4	262,6	239,2	213,2	175,9	127							
VS 30/24	30	40	377				317,5	294,8	273,1	248,6	221,4	182,2	131,2							
VS 30/25	37	50	395,2				333	309,4	287	261,5	233,5	193,1	140,1							
VS 30/26	37	50	410,1				345,5	320,9	297,5	271,1	241,8	199,7	144,5							
VS 30/27	37	50	425				357,9	332,4	308,1	280,5	250	206,1	148,8							
VS 30/28	37	50	439,8				370,3	343,8	318,5	289,9	258,1	212,5	152,9							
VS 30/29	37	50	454,5				382,6	355,2	328,9	299,2	266,2	218,8	157							
VS 30/30	37	50	469,1				394,9	366,4	339,1	308,5	274,1	224,9	160,9							
VS 30/31	45	60	490				412,9	383,6	355,8	324,2	289,4	239,3	173,6							
VS 30/32	45	60	505				425,4	395,2	366,4	333,7	297,7	245,8	177,9							
VS 30/33	45	60	519,8				437,9	406,7	376,9	343,2	305,9	252,2	182,1							
VS 30/34	45	60	534,6				450,3	418,1	387,3	352,6	314	258,6	186,2							
VS 30/35	45	60	549,4				462,6	429,5	397,7	361,9	322	264,8	190,2							
VS 30/36	45	60	564,1				474,9	440,8	408	371,1	329,9	270,9	194,2							
VS 30/37	45	60	578,7				487,1	452	418,2	380,3	337,7	277	198							
VS 30/38	55	75	612,9				517,4	481,6	448,2	409,8	368,6	308,6	229,2							
VS 30/39	55	75	628,4				530,5	493,7	459,4	420	377,6	315,9	234,4							
VS 30/40	55	75	644				543,5	505,8	470,6	430,1	386,6	323,2	239,6							
VS 30/41	55	75	659,4				556,6	517,9	481,7	440,2	395,6	330,5	244,7							
VS 30/42	55	75	674,9				569,5	529,9	492,8	450,3	404,5	337,7	249,8							
VS 30/43	55	75	690,3				582,5	542	503,9	460,3	413,3	344,9	254,8							

VS46

TABLE OF HYDRAULIC PERFORMANCES AT 50Hz

PUMP TYPE	RATED POWER		Q = DELIVERY																	
	kW	HP	m ³ /h	0	5	10	15	20	25	30	35	40	45	50	55	60	65	70	75	80
			l/min	0	83,5	166,5	250	333,5	416,5	500	583,5	666,5	750	833,5	916,5	1000	1083,5	1166,5	1250	1333,5
H = TOTAL HEAD METERS COLUMN OF WATER [m]																				
VS 46/2	3	4	26,4						22,6	20,9	19,3	17,8	16,6	15,1	13,4	11,3				
VS 46/3	4	5,5	39,4						33,8	31,2	28,8	26,6	24,7	22,5	19,9	16,8				
VS 46/4	5,5	7,5	52,5						45	41,5	38,3	35,5	32,9	29,9	26,5	22,3				
VS 46/5	7,5	10	66,1						56,8	52,3	48,3	44,7	41,5	37,8	33,6	28,4				
VS 46/6	9,3	12,5	80,7						70	65,2	60,4	55,5	50,3	46	41,6	35,7				
VS 46/7	9,3	12,5	93,1						80,4	74,8	69,3	63,5	57,6	52,7	47,5	40,5				
VS 46/8	11	15	106,1						91,6	85,1	78,9	72,2	65,5	59,9	54	46				
VS 46/9	15	20	121,5						105,5	98,2	91	83,7	75,9	69,5	62,9	54,1				
VS 46/10	15	20	134						116,1	108	100,1	91,9	83,3	76,2	68,9	59				
VS 46/11	15	20	146,3						126,5	117,6	109	99,9	90,5	82,8	74,7	63,7				
VS 46/12	18,5	25	161,3						140	130,3	120,8	110,9	100,6	92	83,3	71,4				
VS 46/13	18,5	25	173,8						150,5	140	129,8	119	107,9	98,7	89,2	76,3				
VS 46/14	18,5	25	186,1						160,9	149,5	138,7	127	115,1	105,3	95	81				
VS 46/15	22	30	200,8						174,1	161,9	150,1	137,7	124,9	114,3	103,3	88,4				
VS 46/16	22	30	213,2						184,5	171,5	159,1	145,8	132,2	120,9	109,1	93,2				
VS 46/17	22	30	225,4						194,7	181	167,8	153,6	139,3	127,3	114,8	97,8				
VS 46/18	30	40	243,8						212,3	197,6	183,1	168,6	152,9	139,9	126,8	109,2				
VS 46/19	30	40	256,6						223,1	207,7	192,5	177	160,5	146,9	133	114,4				
VS 46/20	30	40	269,2						233,8	217,6	201,7	185,3	168,1	153,7	139,1	119,5				
VS 46/21	30	40	281,8						244,4	227,4	210,8	193,5	175,5	160,5	145,2	124,4				
VS 46/22	30	40	294,2						254,9	237	219,8	201,6	182,8	167,2	151,1	129,3				
VS 46/23	30	40	306,6						265,2	246,6	228,6	209,5	190	173,8	156,9	134				
VS 46/24	37	50	322,4						279,8	260,3	241,3	221,6	200,9	183,8	166,3	142,6				
VS 46/25	37	50	334,9						290,3	270	250,3	229,7	208,3	190,6	172,2	147,5				
VS 46/26	37	50	347,3						300,7	279,6	259,3	237,8	215,6	197,2	178,1	152,3				
VS 46/27	37	50	359,6						311,1	289,2	268,2	245,7	222,8	203,7	183,9	157				
VS 46/28	37	50	371,8						321,3	298,6	276,9	253,6	229,9	210,2	189,6	161,7				
VS 46/29	45	60	390,1						338,7	315,1	292,1	268,3	243,3	222,6	201,4	172,9				
VS 46/30	45	60	402,7						349,2	324,9	301,1	276,5	250,7	229,4	207,4	177,8				
VS 46/31	45	60	415,1						359,6	334,5	310,1	284,5	258	236	213,3	182,6				
VS 46/32	45	60	427,5						370	344,1	319	292,5	265,2	242,6	219,1	187,4				
VS 46/33	45	60	439,8						380,3	353,5	327,8	300,4	272,3	249,1	224,8	192				
VS 46/34	55	75	469,3						410,9	383,1	354,8	328	297,6	271,9	248,1	215,7				
VS 46/35	55	75	482,5						422,3	393,7	364,6	337	305,8	279,4	254,8	221,4				
VS 46/36	55	75	495,7						433,7	404,3	374,4	345,9	313,9	286,8	261,4	227				
VS 46/37	55	75	508,9						445	414,8	384,1	354,8	321,9	294,2	268,1	232,6				
VS 46/38	55	75	522						456,3	425,3	393,8	363,7	330	301,6	274,7	238,2				
VS 46/39	55	75	535,1						467,5	435,7	403,5	372,5	337,9	308,9	281,2	243,8				
VS 46/40	55	75	548,1						478,7	446,1	413,1	381,3	345,9	316,2	287,8	249,3				

VS65

TABLE OF HYDRAULIC PERFORMANCES AT 50Hz

PUMP TYPE	RATED POWER		Q = DELIVERY																	
	kW	HP	m ³ /h	0	5	10	15	20	25	30	35	40	45	50	55	60	65	70	75	80
			l/min	0	83,5	166,5	250	333,5	416,5	500	583,5	666,5	750	833,5	916,5	1000	1083,5	1166,5	1250	1333,5
H = TOTAL HEAD METERS COLUMN OF WATER [m]																				
VS 65/2	3,7	5	26,8								21,1	19	17,3	16,5	15,7	14,9	13,9	12,4	10,5	8,2
VS 65/3	5,5	7,5	40,4								31,8	28,8	26,2	24,9	23,7	22,5	21	18,9	16	12,6
VS 65/4	7,5	10	54								42,5	38,4	35	33,2	31,6	30,1	28	25,2	21,4	16,9
VS 65/5	9,3	12,5	68								53,8	48,7	44,3	41,9	40,1	38,2	35,6	32,2	27,5	22
VS 65/6	11	15	81,2								64	57,9	52,7	50	47,7	45,3	42,3	38,1	32,3	25,7
VS 65/7	15	20	94,9								76,2	70,1	65,2	61,7	58,6	55,7	52,1	46,1	39,7	33,4
VS 65/8	15	20	107,6								86	79,1	73,5	69,7	66,1	62,8	58,5	51,6	44,3	37
VS 65/9	15	20	120,1								95,5	87,8	81,5	77,4	73,4	69,6	64,6	56,8	48,6	40,2
VS 65/10	18,5	25	134,5								107,6	99	91,9	87,2	82,7	78,5	73,2	64,6	55,5	46,3
VS 65/11	18,5	25	147								117,2	107,8	100,1	95	90	85,4	79,4	69,8	59,9	49,6
VS 65/12	22	30	161,2								128,9	118,5	110,1	104,4	99,1	94,1	87,6	77,3	66,3	55,3
VS 65/13	22	30	173,7								138,5	127,3	118,2	112,2	106,4	101	93,8	82,5	70,8	58,6
VS 65/14	30	40	190,3								153,3	141	131,1	124	118	112	104,9	93	80,2	67,7
VS 65/15	30	40	203,2								163,4	150,2	139,6	132,2	125,7	119,3	111,5	98,7	85	71,5
VS 65/16	30	40	216								173,3	159,3	148	140,3	133,2	126,5	118,1	104,3	89,7	75,2
VS 65/17	30	40	228,6								183	168,3	156,3	148,2	140,7	133,5	124,4	109,8	94,3	78,8
VS 65/18	37	50	243,4								195,5	179,8	167	158,2	150,3	142,7	133,3	117,9	101,5	85,2
VS 65/19	37	50	256,1								205,3	188,8	175,4	166,2	157,9	149,9	139,8	123,5	106,1	88,9
VS 65/20	37	50	268,8								215	197,7	183,7	174,1	165,3	156,9	146,2	128,9	110,7	92,4
VS 65/21	37	50	281,4								224,6	206,5	191,8	182	172,6	163,8	152,4	134,2	115,1	95,7
VS 65/22	45	60	297,7								239,2	219,9	204,4	193,6	183,9	174,6	163,2	144,3	124,2	104,4
VS 65/23	45	60	310,5								249	229	212,7	201,6	191,4	181,7	169,6	149,8	128,9	108
VS 65/24	45	60	323,2								258,7	237,9	221	209,5	198,9	188,8	176	155,3	133,4	111,5
VS 65/25	45	60	335,8								268,4	246,7	229,2	217,3	206,2	195,7	182,2	160,6	137,9	114,9
VS 65/26	45	60	348,4								277,9	255,5	237,3	225,1	213,5	202,5	188,3	165,8	142,2	118,1
VS 65/27	55	75	372,8								303	278,8	259,3	244,7	233,4	221,6	208,5	186,4	161,6	137,5
VS 65/28	55	75	386,1								313,5	288,5	268,3	253,3	241,5	229,3	215,7	192,6	166,9	142
VS 65/29	55	75	399,4								324	298,1	277,2	261,8	249,5	237	222,8	198,8	172,2	146,4
VS 65/30	55	75	412,6								334,5	307,7	286,1	270,3	257,6	244,6	229,8	204,9	177,4	150,8
VS 65/31	55	75	425,8								344,9	317,3	295	278,7	265,5	252,2	236,8	211	182,6	155

VS Series Stainless Steel Submersible Pumps for 6" deep wells and larger

Technical Data and Performance Curves

50 Hz

According to COMMISSION REGULATION (EU) No 547/2012

MEI - Minimum Efficiency Index

In order to achieve a comparable efficiency threshold-value across all legally covered water pumps, an index of pump size, specific speed and rotational speed has been created: the MEI (Minimum Efficiency Index).

MEI covers best point (BEP), part load (PL) and overload (OL) efficiencies as water pumps may be chosen with safety margins and hence do not run at best efficiency point.

This ensures high and flat efficiency curves and consequently an efficient operation in real life.

MEI means the dimensionless scale unit for hydraulic pump efficiency at BEP, PL and OL.

MEI is a measure for the quality of a pump size in respect to the efficiency.

The higher the value of the MEI is, the better is the pump size in respect to efficiency and the lower is the yearly energy consumption if pumps of this size are installed.

The upper limit of values of the MEI is principally open and depends only on physical and technological constraints. MEI is based on the full impeller diameter.

The operation of this water pump with variable duty points may be more efficient and economic when controlled, for example, by the use of a variable speed drive that matches the pump duty to the system Benchmark $MEI \geq 0,70$.

For benchmark efficiency graphs, go to www.europump.org/efficiencycharts.

Information on benchmark efficiency is available at www.etechpumps.com.

Pumps with Encapsulated Motor

Pump model type	Motor			Dimensions					Weight Pump [Kg]
	Type	kW	HP	L1 [mm]	L2 [mm]	Lt [mm]	D		
							1 cable	2 cable	
VS 14/5	E4	2,2	3	413,5	422	835,5	142,5	-	26,5
VS 14/6	E4	3,7	5	443,5	520	963,5	142,5	-	32
VS 14/7	E4	3,7	5	473,5	520	993,5	142,5	-	32
VS 14/8	E4	3,7	5	503,5	520	1023,5	142,5	-	33
VS 14/9	E4	5,5	7,5	533,5	652,5	1186	142,5	-	41
VS 14/10	E4	5,5	7,5	563,5	652,5	1216	142,5	-	41,5
VS 14/11	E4	5,5	7,5	593,5	652,5	1246	142,5	-	42,5
VS 14/12	E4	5,5	7,5	623,5	652,5	1276	142,5	-	43,5
VS 14/13	E4	5,5	7,5	653,5	652,5	1306	142,5	-	44
VS 14/14	E4	7,5	10	683,5	730,5	1414	142,5	-	49
VS 14/15	E4	7,5	10	713,5	730,5	1444	142,5	-	49,5
VS 14/16	E4	7,5	10	743,5	730,5	1474	142,5	-	50,5
VS 14/17	E4	7,5	10	773,5	730,5	1504	142,5	-	51
VS 14/5	E6	4	5,5	411	581	992	143	144,5	49
VS 14/6	E6	4	5,5	441	581	1022	143	144,5	50
VS 14/7	E6	4	5,5	471	581	1052	143	144,5	50,5
VS 14/8	E6	4	5,5	501	581	1082	143	144,5	51,5
VS 14/9	E6	5,5	7,5	531	614,5	1145,5	143	144,5	55,5
VS 14/10	E6	5,5	7,5	561	614,5	1175,5	143	144,5	56
VS 14/11	E6	5,5	7,5	591	614,5	1205,5	143	144,5	57
VS 14/12	E6	5,5	7,5	621	614,5	1235,5	143	144,5	58
VS 14/13	E6	5,5	7,5	651	614,5	1265,5	143	144,5	58,5
VS 14/14	E6	7,5	10	681	646	1327	143	144,5	63,5
VS 14/15	E6	7,5	10	711	646	1357	143	144,5	64
VS 14/16	E6	7,5	10	741	646	1387	143	144,5	65
VS 14/17	E6	7,5	10	771	646	1417	143	144,5	65,5
VS 14/18	E6	9,3	12,5	801	678,5	1479,5	143	144,5	69
VS 14/19	E6	9,3	12,5	831	678,5	1509,5	143	144,5	69,5
VS 14/20	E6	9,3	12,5	861	678,5	1539,5	143	144,5	70,5
VS 14/21	E6	9,3	12,5	891	678,5	1569,5	143	144,5	71
VS 14/22	E6	9,3	12,5	921	678,5	1599,5	143	144,5	71,5
VS 14/23	E6	11	15	951	711	1662	143	144,5	76
VS 14/24	E6	11	15	981	711	1692	143	144,5	76,5
VS 14/25	E6	11	15	1011	711	1722	143	144,5	77,5
VS 14/26	E6	11	15	1041	711	1752	143	144,5	78

Pumps with Rewindable Motor

Pump model type	Motor			Dimensions					Weight Pump [Kg]
	Type	kW	HP	L1 [mm]	L2 [mm]	Lt [mm]	D		
							1 cable	2 cable	
VS 14/5	RW6	4	5,5	411	699	1110	147	147,5	59,5
VS 14/6	RW6	4	5,5	441	699	1140	147	147,5	60,5
VS 14/7	RW6	4	5,5	471	699	1170	147	147,5	61
VS 14/8	RW6	4	5,5	501	699	1200	147	147,5	62
VS 14/9	RW6	5,5	7,5	531	699	1230	147	147,5	62,5
VS 14/10	RW6	5,5	7,5	561	699	1260	147	147,5	63
VS 14/11	RW6	5,5	7,5	591	699	1290	147	147,5	64
VS 14/12	RW6	5,5	7,5	621	699	1320	147	147,5	65
VS 14/13	RW6	5,5	7,5	651	699	1350	147	147,5	65,5
VS 14/14	RW6	7,5	10	681	719	1400	147	147,5	68,5
VS 14/15	RW6	7,5	10	711	719	1430	147	147,5	69
VS 14/16	RW6	7,5	10	741	719	1460	147	147,5	70
VS 14/17	RW6	7,5	10	771	719	1490	147	147,5	70,5
VS 14/18	RW6	9,3	12,5	801	749	1550	147	147,5	74,5
VS 14/19	RW6	9,3	12,5	831	749	1580	147	147,5	75
VS 14/20	RW6	9,3	12,5	861	749	1610	147	147,5	76
VS 14/21	RW6	9,3	12,5	891	749	1640	147	147,5	76,5
VS 14/22	RW6	9,3	12,5	921	749	1670	147	147,5	77
VS 14/23	RW6	11	15	951	699	1650	147	147,5	81
VS 14/24	RW6	11	15	981	719	1700	147	147,5	81,5
VS 14/25	RW6	11	15	1011	749	1760	147	147,5	82,5
VS 14/26	RW6	11	15	1041	779	1820	147	147,5	83

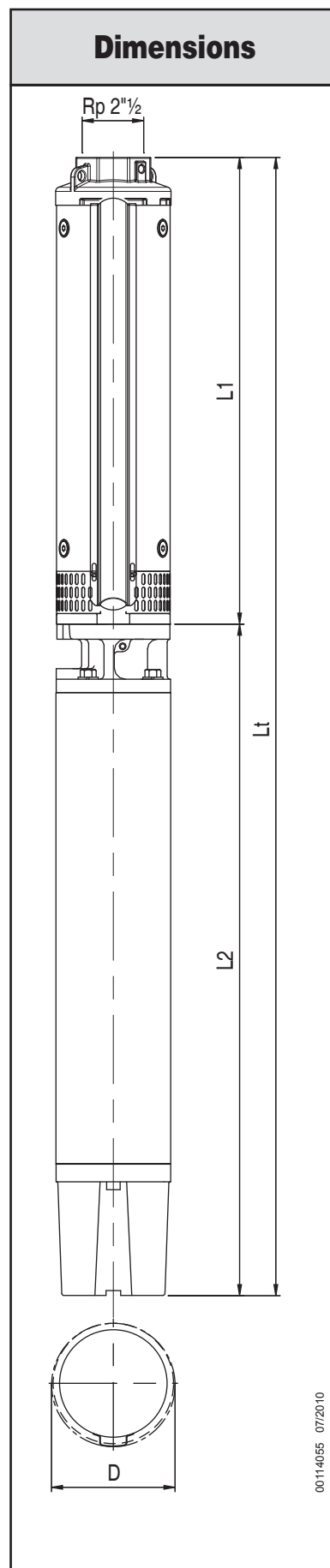

00114055 07/2010

Performance curves 50Hz

MEI ≥ 0,10

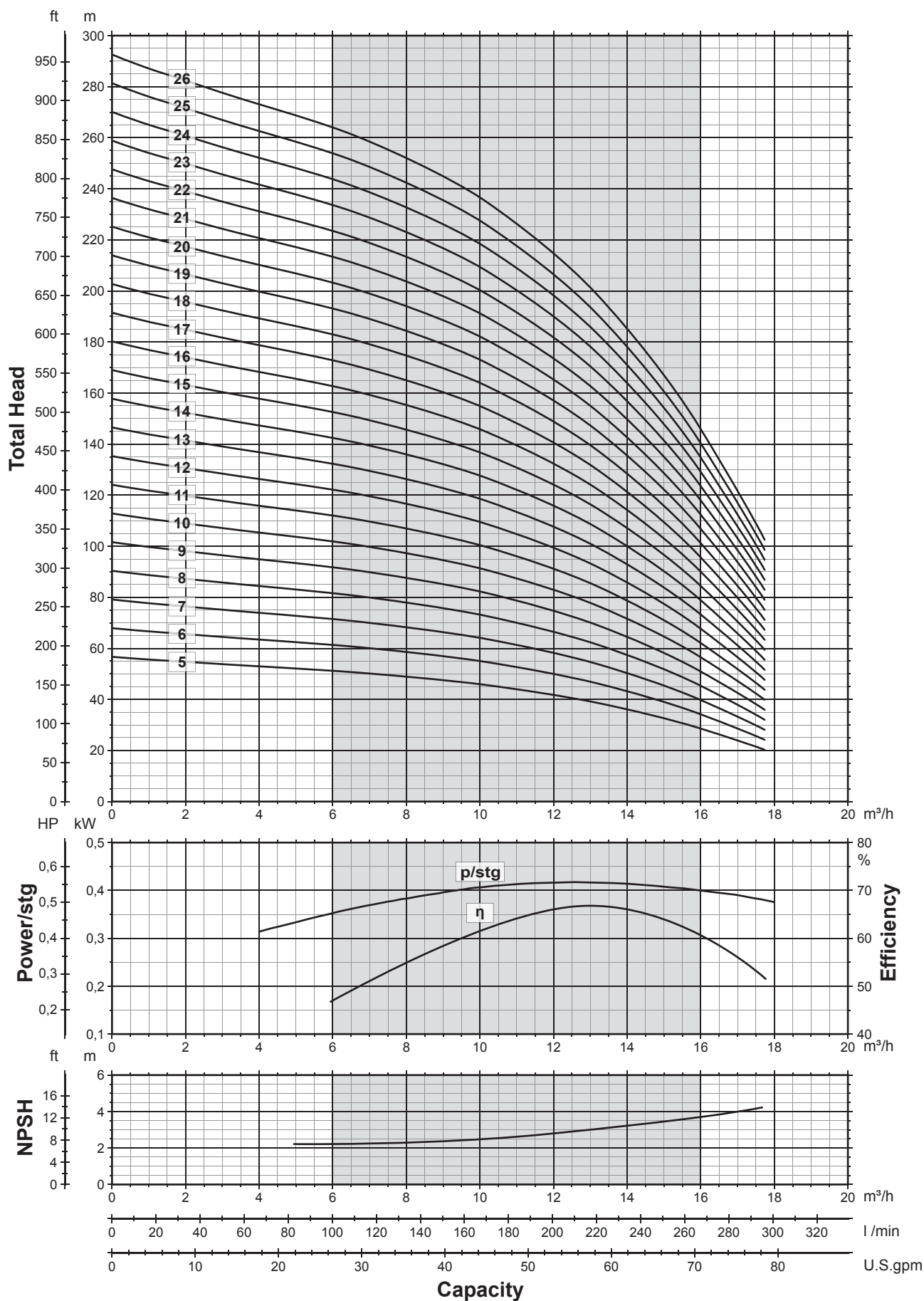

Pumps with Encapsulated Motor

Pump model type	Motor			Dimensions					Weight Pump [Kg]
	Type	kW	HP	L1 [mm]	L2 [mm]	Lt [mm]	D		
							1 cable	2 cable	
VS 14/27	E6	15	20	1071	776	1847	143	144,5	85,5
VS 14/28	E6	15	20	1101	776	1877	143	144,5	85,5
VS 14/29	E6	15	20	1131	776	1907	143	144,5	87
VS 14/30	E6	15	20	1161	776	1937	143	144,5	87,5
VS 14/31	E6	15	20	1191	776	1967	143	144,5	87,5
VS 14/32	E6	15	20	1220,5	776	1996,5	143	144,5	88
VS 14/33	E6	15	20	1250,5	776	2026,5	143	144,5	89
VS 14/34	E6	15	20	1280,5	776	2056,5	143	144,5	90
VS 14/35	E6	15	20	1310,5	776	2086,5	143	144,5	90,5
VS 14/36	E6	15	20	1340,5	776	2116,5	143	144,5	91
VS 14/37	E6	18,5	25	1370,5	841,5	2212	143	144,5	99
VS 14/38	E6	18,5	25	1400,5	841,5	2242	143	144,5	99,5
VS 14/39	E6	18,5	25	1430,5	841,5	2272	143	144,5	101
VS 14/40	E6	18,5	25	1460,5	841,5	2302	143	144,5	102
VS 14/41	E6	18,5	25	1490,5	841,5	2332	143	144,5	102,5
VS 14/42	E6	18,5	25	1520,5	841,5	2362	143	144,5	102,5
VS 14/43	E6	18,5	25	1550,5	841,5	2392	143	144,5	103,5
VS 14/44	E6	18,5	25	1580,5	841,5	2422	143	144,5	104
VS 14/45	E6	22	30	1610,5	906,5	2517	143	144,5	111
VS 14/46	E6	22	30	1640,5	906,5	2547	143	144,5	111,5
VS 14/47	E6	22	30	1670,5	906,5	2577	143	144,5	112,5
VS 14/48	E6	22	30	1700	906,5	2606,5	143	144,5	113,5
VS 14/49	E6	22	30	1730,5	906,5	2637	143	144,5	114,5

Pumps with Rewindable Motor

Pump model type	Motor			Dimensions					Weight Pump [Kg]
	Type	kW	HP	L1 [mm]	L2 [mm]	Lt [mm]	D		
							1 cable	2 cable	
VS 14/27	RW6	13	17,5	1071	829	1900	147	147,5	90
VS 14/28	RW6	13	17,5	1101	829	1930	147	147,5	90
VS 14/29	RW6	13	17,5	1131	829	1960	147	147,5	91,5
VS 14/30	RW6	13	17,5	1161	829	1990	147	147,5	92
VS 14/31	RW6	13	17,5	1191	829	2020	147	147,5	92
VS 14/32	RW6	15	20	1220,5	874	2094,5	147	147,5	97,5
VS 14/33	RW6	15	20	1250,5	874	2124,5	147	147,5	98,5
VS 14/34	RW6	15	20	1280,5	874	2154,5	147	147,5	99,5
VS 14/35	RW6	15	20	1310,5	874	2184,5	147	147,5	100
VS 14/36	RW6	15	20	1340,5	874	2214,5	147	147,5	100,5
VS 14/37	RW6	18,5	25	1370,5	919	2289,5	147	147,5	105,5
VS 14/38	RW6	18,5	25	1400,5	919	2319,5	147	147,5	106
VS 14/39	RW6	18,5	25	1430,5	919	2349,5	147	147,5	107,5
VS 14/40	RW6	18,5	25	1460,5	919	2379,5	147	147,5	108,5
VS 14/41	RW6	18,5	25	1490,5	919	2409,5	147	147,5	109
VS 14/42	RW6	18,5	25	1520,5	919	2439,5	147	147,5	109
VS 14/43	RW6	18,5	25	1550,5	919	2469,5	147	147,5	110
VS 14/44	RW6	18,5	25	1580,5	919	2499,5	147	147,5	110,5
VS 14/45	RW6	22	30	1610,5	1009	2619,5	147	147,5	120,5
VS 14/46	RW6	22	30	1640,5	1009	2649,5	147	147,5	121
VS 14/47	RW6	22	30	1670,5	1009	2679,5	147	147,5	122
VS 14/48	RW6	22	30	1700	1009	2709	147	147,5	123
VS 14/49	RW6	22	30	1730,5	1009	2739,5	147	147,5	124

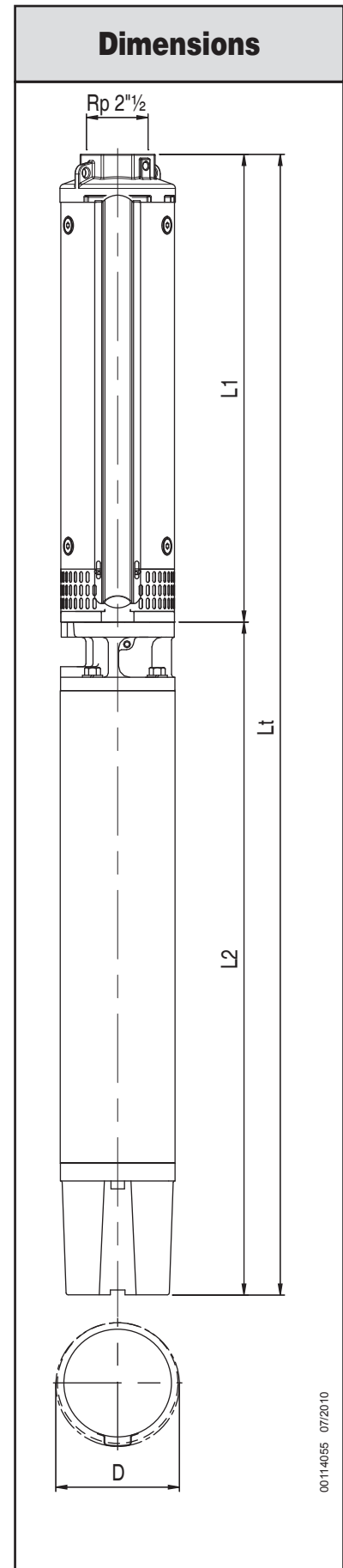

00114055 07/2010

Performance curves 50Hz

MEI ≥ 0,10

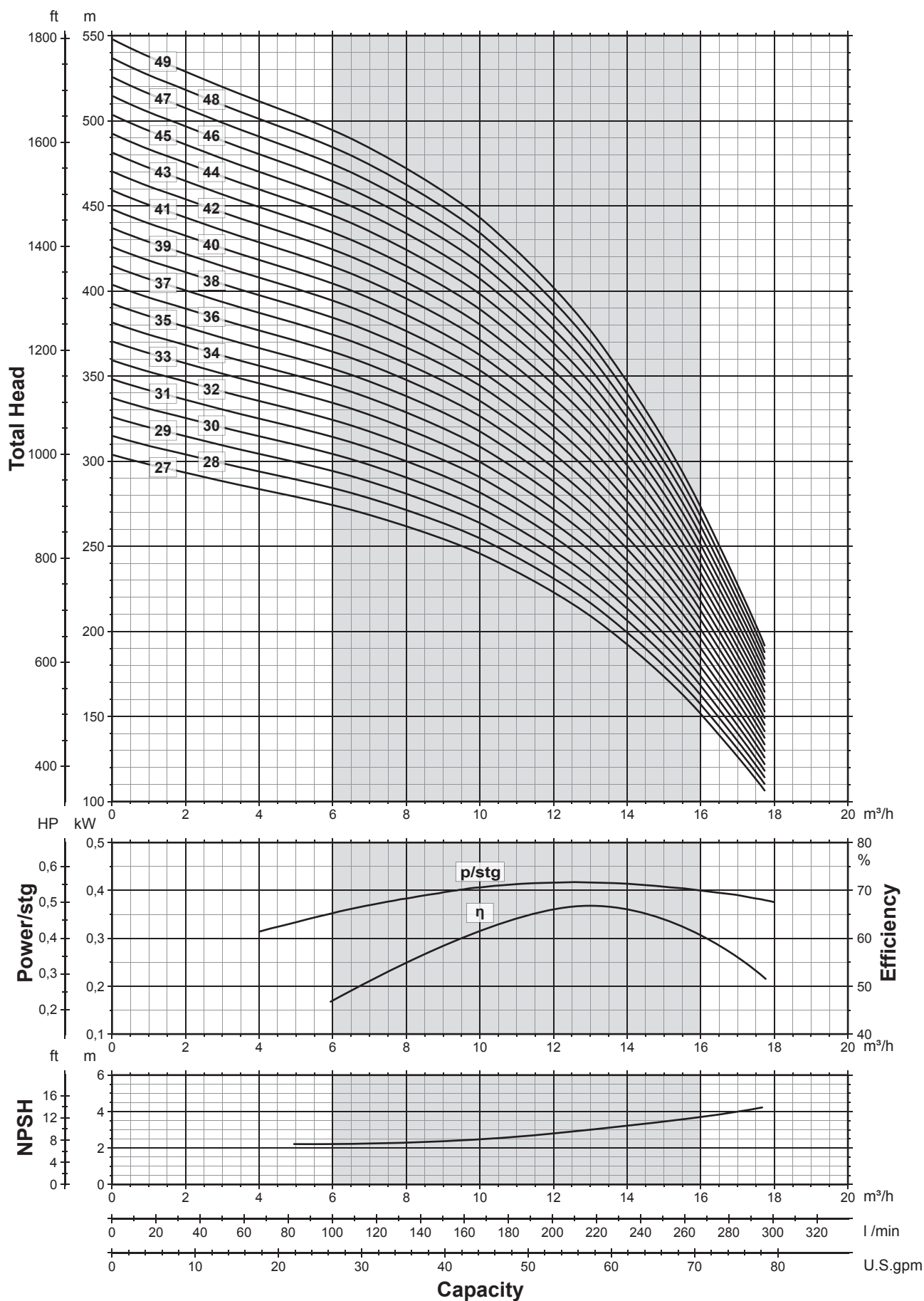

Performance curves 50Hz

MEI ≥ 0,10

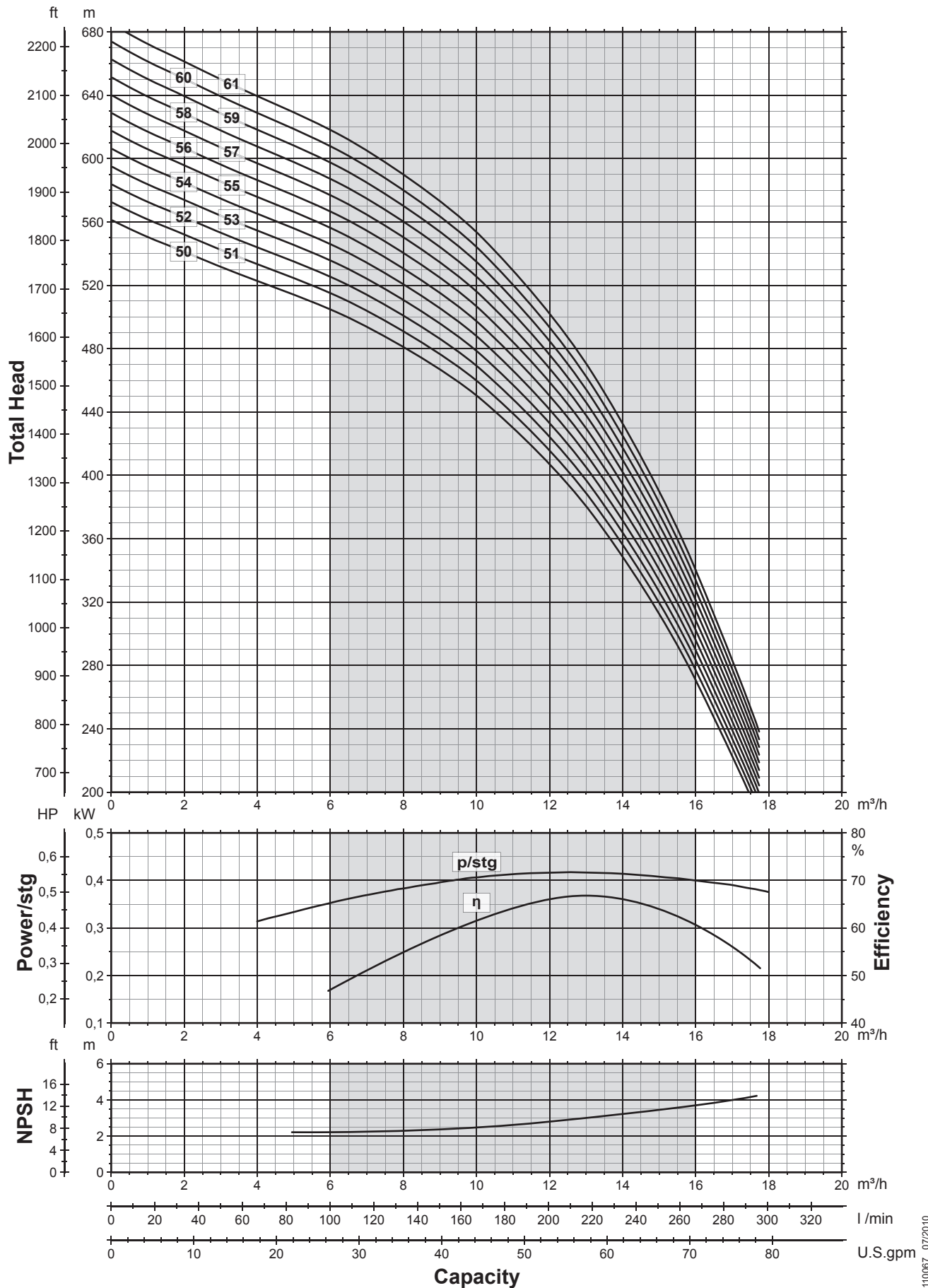

Pumps with Encapsulated Motor

Pump model type	Motor			Dimensions					Weight Pump [Kg]
	Type	kW	HP	L1 [mm]	L2 [mm]	Lt [mm]	D		
							1 cable	2 cable	
VS 19/6	E4	3,7	5	497,5	520	1017,5	142,5	-	31,5
VS 19/7	E4	5,5	7,5	535	652,5	1187,5	142,5	-	40
VS 19/8	E4	5,5	7,5	572,5	652,5	1225	142,5	-	41
VS 19/9	E4	5,5	7,5	610	652,5	1262,5	142,5	-	41,5
VS 19/10	E4	7,5	10	647,5	730,5	1378	142,5	-	46,5
VS 19/11	E4	7,5	10	685	730,5	1415,5	142,5	-	47,5
VS 19/12	E4	7,5	10	722,5	730,5	1453	142,5	-	48
VS 19/6	E6	4	5,5	495	581	1076	143	144,5	50
VS 19/7	E6	5,5	7,5	532,5	614,5	1147	143	144,5	54,5
VS 19/8	E6	5,5	7,5	570	614,5	1184,5	143	144,5	55,5
VS 19/9	E6	5,5	7,5	607,5	614,5	1222	143	144,5	56
VS 19/10	E6	7,5	10	645	646	1291	143	144,5	61
VS 19/11	E6	7,5	10	682,5	646	1328,5	143	144,5	62
VS 19/12	E6	7,5	10	720	646	1366	143	144,5	62,5
VS 19/13	E6	9,3	12,5	757,5	678,5	1436	143	144,5	66
VS 19/14	E6	9,3	12,5	795	678,5	1473,5	143	144,5	67
VS 19/15	E6	9,3	12,5	832,5	678,5	1511	143	144,5	67,5
VS 19/16	E6	11	15	870	711	1581	143	144,5	72
VS 19/17	E6	11	15	907,5	711	1618,5	143	144,5	73
VS 19/18	E6	11	15	945	711	1656	143	144,5	73,5
VS 19/19	E6	15	20	982,5	776	1758,5	143	144,5	80
VS 19/20	E6	15	20	1020	776	1796	143	144,5	80,5
VS 19/21	E6	15	20	1057,5	776	1833,5	143	144,5	81,5
VS 19/22	E6	15	20	1095	776	1871	143	144,5	82,5
VS 19/23	E6	15	20	1132,5	776	1908,5	143	144,5	83
VS 19/24	E6	15	20	1170	776	1946	143	144,5	84

Pumps with Rewindable Motor

Pump model type	Motor			Dimensions					Weight Pump [Kg]
	Type	kW	HP	L1 [mm]	L2 [mm]	Lt [mm]	D		
							1 cable	2 cable	
VS 19/6	RW6	4	5,5	495	699	1194	147	147,5	60,5
VS 19/7	RW6	5,5	7,5	532,5	699	1231,5	147	147,5	61,5
VS 19/8	RW6	5,5	7,5	570	699	1269	147	147,5	62,5
VS 19/9	RW6	5,5	7,5	607,5	699	1306,5	147	147,5	63
VS 19/10	RW6	7,5	10	645	719	1364	147	147,5	66
VS 19/11	RW6	7,5	10	682,5	719	1401,5	147	147,5	67
VS 19/12	RW6	7,5	10	720	719	1439	147	147,5	67,5
VS 19/13	RW6	9,3	12,5	757,5	749	1506,5	147	147,5	71,5
VS 19/14	RW6	9,3	12,5	795	749	1544	147	147,5	72,5
VS 19/15	RW6	9,3	12,5	832,5	749	1581,5	147	147,5	73
VS 19/16	RW6	11	15	870	779	1649	147	147,5	77
VS 19/17	RW6	11	15	907,5	779	1686,5	147	147,5	78
VS 19/18	RW6	11	15	945	779	1724	147	147,5	78,5
VS 19/19	RW6	13	17,5	982,5	829	1811,5	147	147,5	84,5
VS 19/20	RW6	13	17,5	1020	829	1849	147	147,5	85
VS 19/21	RW6	13	17,5	1057,5	829	1886,5	147	147,5	86
VS 19/22	RW6	15	20	1095	874	1969	147	147,5	92
VS 19/23	RW6	15	20	1132,5	874	2006,5	147	147,5	92,5
VS 19/24	RW6	15	20	1170	874	2044	147	147,5	93,5

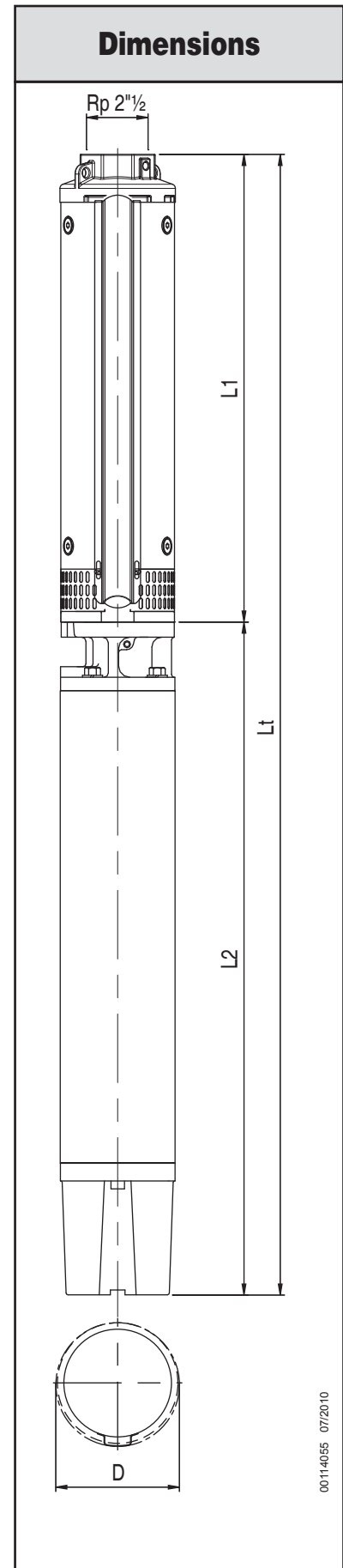

00114055 07/2010

Performance curves 50Hz

MEI ≥ 0,10

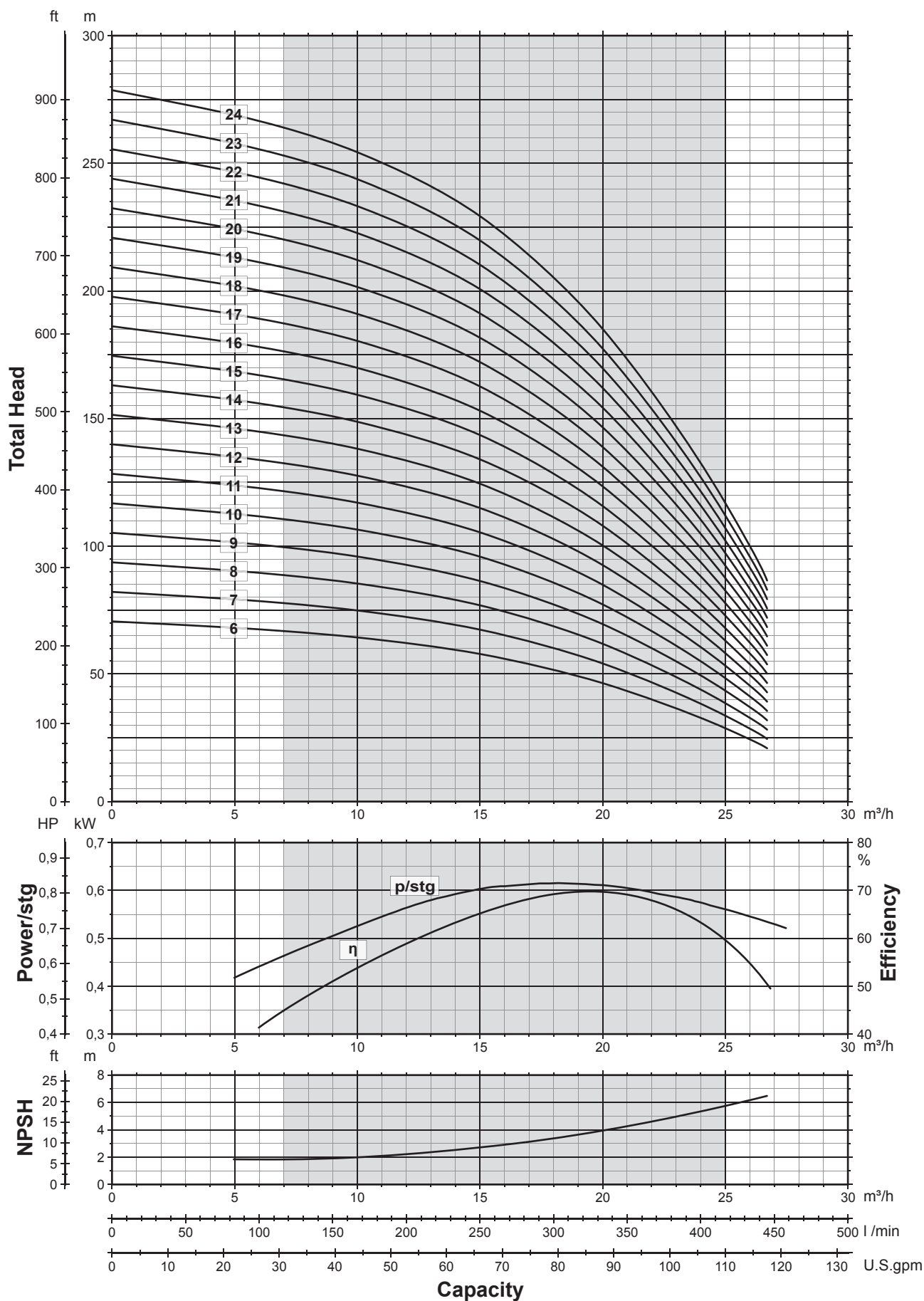

00110067 07/2010

Pumps with Encapsulated Motor

Pump model type	Motor			Dimensions					Weight Pump [Kg]
	Type	kW	HP	L1 [mm]	L2 [mm]	Lt [mm]	D		
							1 cable	2 cable	
VS 19/25	E6	18,5	25	1207,5	841,5	2049	143	144,5	92
VS 19/26	E6	18,5	25	1245	841,5	2086,5	143	144,5	92,5
VS 19/27	E6	18,5	25	1282,5	841,5	2124	143	144,5	94,5
VS 19/28	E6	18,5	25	1319,5	841,5	2161	143	144,5	94,5
VS 19/29	E6	18,5	25	1357	841,5	2198,5	143	144,5	95
VS 19/30	E6	18,5	25	1394,5	841,5	2236	143	144,5	96
VS 19/31	E6	22	30	1432	906,5	2338,5	143	144,5	103
VS 19/32	E6	22	30	1469,5	906,5	2376	143	144,5	103,5
VS 19/33	E6	22	30	1507	906,5	2413,5	143	144,5	104,5
VS 19/34	E6	22	30	1544,5	906,5	2451	143	144,5	105
VS 19/35	E6	22	30	1582	906,5	2488,5	143	144,5	106
VS 19/36	E6	22	30	1619,5	906,5	2526	143	144,5	106,5
VS 19/37	E6	30	40	1657	1036,5	2693,5	143	144,5	122,5
VS 19/38	E6	30	40	1694,5	1036,5	2731	143	144,5	124
VS 19/39	E6	30	40	1732	1036,5	2768,5	143	144,5	124
VS 19/40	E6	30	40	1769,5	1036,5	2806	143	144,5	124,5
VS 19/41	E6	30	40	1807	1036,5	2843,5	143	144,5	126
VS 19/42	E6	30	40	1844,5	1036,5	2881	143	144,5	127
VS 19/43	E6	30	40	1882	1036,5	2918,5	143	144,5	128
VS 19/44	E6	30	40	1919,5	1036,5	2956	143	144,5	129
VS 19/45	E6	30	40	1957	1036,5	2993,5	143	144,5	130
VS 19/46	E6	30	40	1994	1036,5	3030,5	143	144,5	131

Pumps with Rewindable Motor

Pump model type	Motor			Dimensions					Weight Pump [Kg]
	Type	kW	HP	L1 [mm]	L2 [mm]	Lt [mm]	D		
							1 cable	2 cable	
VS 19/25	RW6	18,5	25	1207,5	919	2126,5	147	147,5	98,5
VS 19/26	RW6	18,5	25	1245	919	2164	147	147,5	99
VS 19/27	RW6	18,5	25	1282,5	919	2201,5	147	147,5	101
VS 19/28	RW6	18,5	25	1319,5	919	2238,5	147	147,5	101
VS 19/29	RW6	18,5	25	1357	919	2276	147	147,5	101,5
VS 19/30	RW6	18,5	25	1394,5	919	2313,5	147	147,5	102,5
VS 19/31	RW6	22	30	1432	1009	2441	147	147,5	112,5
VS 19/32	RW6	22	30	1469,5	1009	2478,5	147	147,5	113
VS 19/33	RW6	22	30	1507	1009	2516	147	147,5	114
VS 19/34	RW6	22	30	1544,5	1009	2553,5	147	147,5	114,5
VS 19/35	RW6	22	30	1582	1009	2591	147	147,5	115,5
VS 19/36	RW6	22	30	1619,5	1009	2628,5	147	147,5	116
VS 19/37	RW6	26	35	1657	1114	2771	147	147,5	128,5
VS 19/38	RW6	26	35	1694,5	1114	2808,5	147	147,5	130
VS 19/39	RW6	26	35	1732	1114	2846	147	147,5	130
VS 19/40	RW6	26	35	1769,5	1114	2883,5	147	147,5	130,5
VS 19/41	RW6	26	35	1807	1114	2921	147	147,5	132
VS 19/42	RW6	26	35	1844,5	1114	2958,5	147	147,5	133
VS 19/43	RW6	30	40	1882	1214	3096	147	147,5	144
VS 19/44	RW6	30	40	1919,5	1214	3133,5	147	147,5	145
VS 19/45	RW6	30	40	1957	1214	3171	147	147,5	146
VS 19/46	RW6	30	40	1994	1214	3208	147	147,5	147

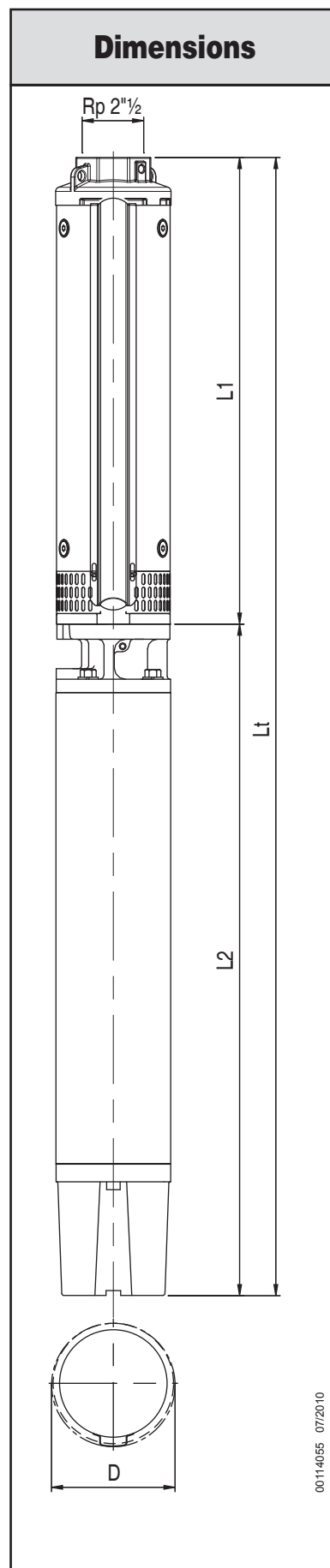

00114055 07/2010

Performance curves 50Hz

MEI ≥ 0,10

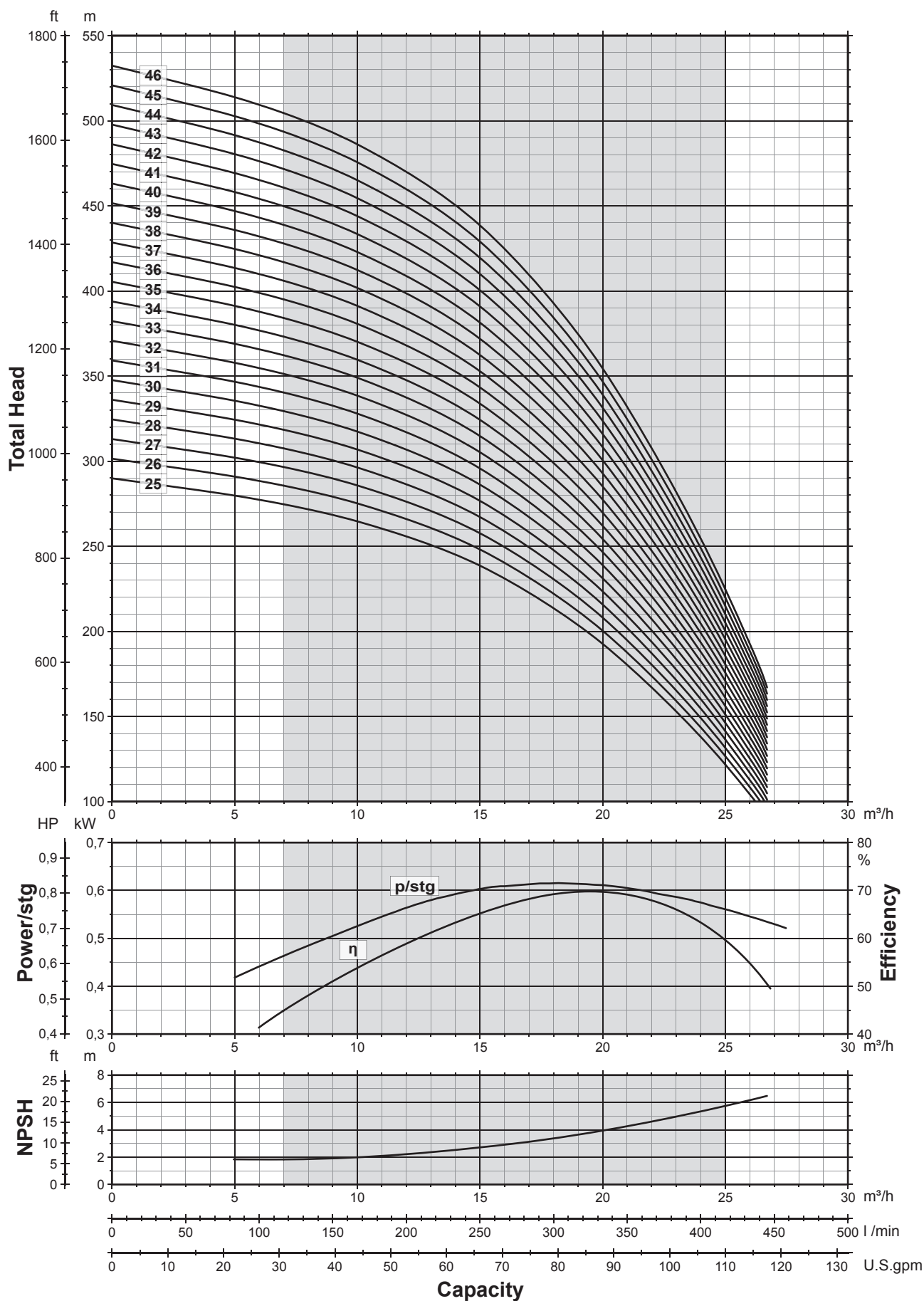

00110067 07/2010

Pumps with Encapsulated Motor

Pump model type	Motor			Dimensions					Weight Pump [Kg]
	Type	kW	HP	L1 [mm]	L2 [mm]	Lt [mm]	D		
							1 cable	2 cable	
VS 19/47	E6	30	40	2031,5	1036,5	3068	145	146,5	131,5
VS 19/48	E6	30	40	2069	1036,5	3105,5	145	146,5	132
VS 19/49	E6	30	40	2106,5	1036,5	3143	145	146,5	134
VS 19/50	E6	37	50	2144	1421,5	3565,5	145	146,5	189
VS 19/51	E6	37	50	2181,5	1421,5	3603	145	146,5	190
VS 19/52	E6	37	50	2219	1421,5	3640,5	145	146,5	191
VS 19/53	E6	37	50	2256,5	1421,5	3678	145	146,5	192
VS 19/54	E6	37	50	2294	1421,5	3715,5	145	146,5	193
VS 19/55	E6	37	50	2331,5	1421,5	3753	145	146,5	194
VS 19/56	E6	37	50	2369	1421,5	3790,5	145	146,5	195
VS 19/57	E6	37	50	2406,5	1421,5	3828	145	146,5	196
VS 19/58	E6	37	50	2444	1421,5	3865,5	145	146,5	197
VS 19/59	E6	37	50	2481,5	1421,5	3903	145	146,5	198
VS 19/60	E6	37	50	2519	1421,5	3940,5	145	146,5	199

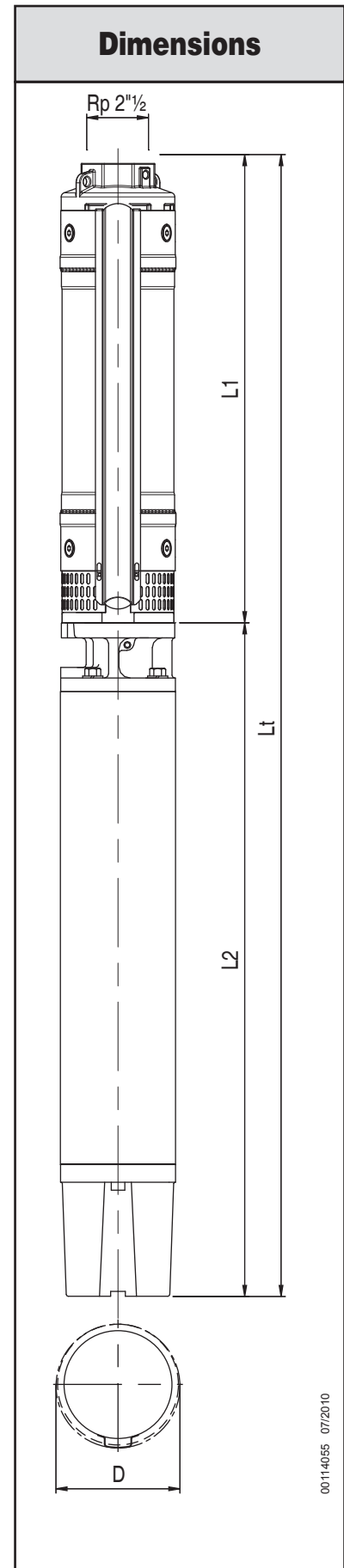

Pumps with Rewindable Motor

Pump model type	Motor			Dimensions					Weight Pump [Kg]
	Type	kW	HP	L1 [mm]	L2 [mm]	Lt [mm]	D		
							1 cable	2 cable	
VS 19/47	RW6	30	40	2031,5	1214	3245,5	149	149,5	147,5
VS 19/48	RW6	30	40	2069	1214	3283	149	149,5	148
VS 19/49	RW6	30	40	2106,5	1214	3320,5	149	149,5	150
VS 19/50	RW6	37	50	2144	1294	3438	149	149,5	158
VS 19/51	RW6	37	50	2181,5	1294	3475,5	149	149,5	159
VS 19/52	RW6	37	50	2219	1294	3513	149	149,5	160
VS 19/53	RW6	37	50	2256,5	1294	3550,5	149	149,5	161
VS 19/54	RW6	37	50	2294	1294	3588	149	149,5	162
VS 19/55	RW6	37	50	2331,5	1294	3625,5	149	149,5	163
VS 19/56	RW6	37	50	2369	1294	3663	149	149,5	164
VS 19/57	RW6	37	50	2406,5	1294	3700,5	149	149,5	165
VS 19/58	RW6	37	50	2444	1294	3738	149	149,5	166
VS 19/59	RW6	37	50	2481,5	1294	3775,5	149	149,5	167
VS 19/60	RW6	37	50	2519	1294	3813	149	149,5	168

00114055 07/2010

Performance curves 50Hz

MEI ≥ 0,10

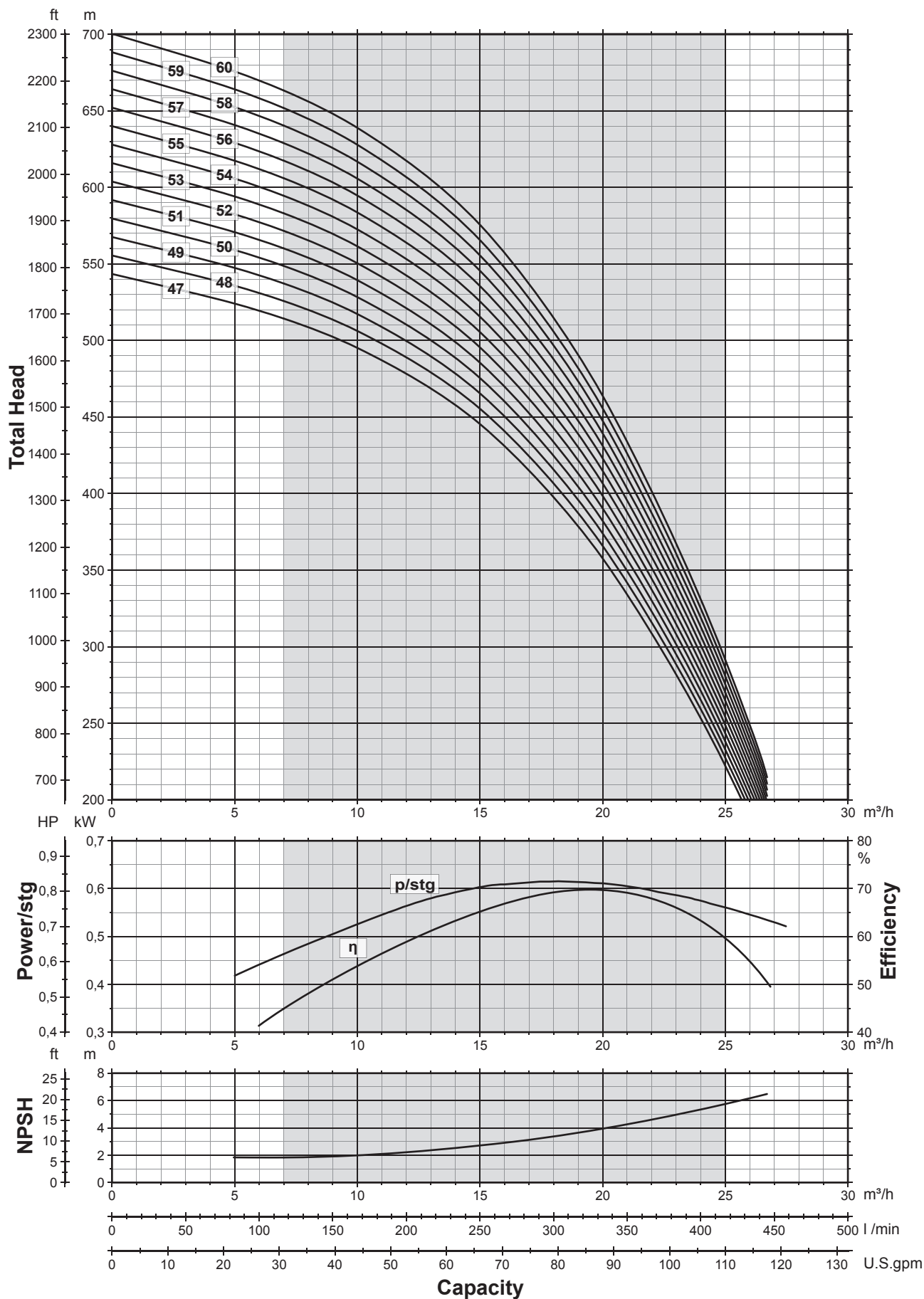

Pumps with Encapsulated Motor

Pump model type	Motor			Dimensions					Weight Pump [Kg]
	Type	kW	HP	L1 [mm]	L2 [mm]	Lt [mm]	D		
							1 cable	2 cable	
VS 30/3	E4	3,7	5	622	520	1142	142,5	-	34
VS 30/4	E4	5,5	7,5	707,5	652,5	1360	142,5	-	43,5
VS 30/5	E4	7,5	10	793	730,5	1523,5	142,5	-	50
VS 30/6	E4	7,5	10	878,5	730,5	1609	142,5	-	52
VS 30/3	E6	4	5,5	620	581	1201	143	144,5	52
VS 30/4	E6	5,5	7,5	705,5	614,5	1320	143	144,5	58
VS 30/5	E6	7,5	10	790,5	646	1436,5	143	144,5	64
VS 30/6	E6	7,5	10	876	646	1522	143	144,5	66
VS 30/7	E6	9,3	12,5	961,5	678,5	1640	143	144,5	70,5
VS 30/8	E6	11	15	1047	711	1758	143	144,5	76,5
VS 30/9	E6	11	15	1132,5	711	1843,5	143	144,5	78,5
VS 30/10	E6	15	20	1218	776	1994	143	144,5	86
VS 30/11	E6	15	20	1303,5	776	2079,5	143	144,5	88
VS 30/12	E6	15	20	1389	776	2165	143	144,5	90
VS 30/13	E6	18,5	25	1474,5	841,5	2316	143	144,5	99
VS 30/14	E6	18,5	25	1560	841,5	2401,5	143	144,5	101,5
VS 30/15	E6	22	30	1645,5	906,5	2552	143	144,5	109,5
VS 30/16	E6	22	30	1730,5	906,5	2637	143	144,5	111,5
VS 30/17	E6	22	30	1816	906,5	2722,5	143	144,5	113,5
VS 30/18	E6	22	30	1901,5	906,5	2808	143	144,5	115,5
VS 30/19	E6	30	40	1987	1036,5	3023,5	143	144,5	132
VS 30/20	E6	30	40	2072,5	1036,5	3109	143	144,5	134,5
VS 30/21	E6	30	40	2157,5	1036,5	3194	143	144,5	136,5
VS 30/22	E6	30	40	2243	1036,5	3279,5	143	144,5	138,5
VS 30/23	E6	30	40	2328,5	1036,5	3365	143	144,5	140,5
VS 30/24	E6	30	40	2414	1036,5	3450,5	143	144,5	142,5
VS 30/25	E6	37	50	2499	1421,5	3920,5	143	144,5	199
VS 30/26	E6	37	50	2584,5	1421,5	4006	143	144,5	201
VS 30/27	E6	37	50	2670	1421,5	4091,5	143	144,5	203
VS 30/28	E6	37	50	2755	1421,5	4176,5	143	144,5	205
VS 30/29	E6	37	50	2840,5	1421,5	4262	143	144,5	207
VS 30/30	E6	37	50	2926	1421,5	4347,5	143	144,5	209,5
VS 30/31	E6	45	60	3011	1574	4585	143	144,5	224,5
VS 30/32	E6	45	60	3096,5	1574	4670,5	143	144,5	227,5
VS 30/33	E6	45	60	3182	1574	4756	143	144,5	229,5
VS 30/34	E6	45	60	3267,5	1574	4841,5	143	144,5	231,5
VS 30/35	E6	45	60	3352,5	1574	4926,5	143	144,5	234

Pumps with Rewindable Motor

Pump model type	Motor			Dimensions					Weight Pump [Kg]
	Type	kW	HP	L1 [mm]	L2 [mm]	Lt [mm]	D		
							1 cable	2 cable	
VS 30/3	RW6	4	5,5	620	699	1319	147	147,5	62,5
VS 30/4	RW6	5,5	7,5	705,5	699	1404,5	147	147,5	65
VS 30/5	RW6	7,5	10	790,5	719	1509,5	147	147,5	69
VS 30/6	RW6	7,5	10	876	719	1595	147	147,5	71
VS 30/7	RW6	9,3	12,5	961,5	749	1710,5	147	147,5	76
VS 30/8	RW6	11	15	1047	779	1826	147	147,5	81,5
VS 30/9	RW6	11	15	1132,5	779	1911,5	147	147,5	83,5
VS 30/10	RW6	13	17,5	1218	829	2047	147	147,5	90,5
VS 30/11	RW6	15	20	1303,5	874	2177,5	147	147,5	97,5
VS 30/12	RW6	15	20	1389	874	2263	147	147,5	99,5
VS 30/13	RW6	18,5	25	1474,5	919	2393,5	147	147,5	105,5
VS 30/14	RW6	18,5	25	1560	919	2479	147	147,5	108
VS 30/15	RW6	22	30	1645,5	1009	2654,5	147	147,5	119
VS 30/16	RW6	22	30	1730,5	1009	2739,5	147	147,5	121
VS 30/17	RW6	22	30	1816	1009	2825	147	147,5	123
VS 30/18	RW6	22	30	1901,5	1009	2910,5	147	147,5	125
VS 30/19	RW6	26	35	1987	1114	3101	147	147,5	138
VS 30/20	RW6	26	35	2072,5	1114	3186,5	147	147,5	140,5
VS 30/21	RW6	26	35	2157,5	1114	3271,5	147	147,5	142,5
VS 30/22	RW6	30	40	2243	1214	3457	147	147,5	154,5
VS 30/23	RW6	30	40	2328,5	1214	3542,5	147	147,5	156,5
VS 30/24	RW6	30	40	2414	1214	3628	147	147,5	158,5
VS 30/25	RW6	37	50	2499	1294	3793	147	147,5	168
VS 30/26	RW6	37	50	2584,5	1294	3878,5	147	147,5	170
VS 30/27	RW6	37	50	2670	1294	3964	147	147,5	172
VS 30/28	RW6	37	50	2755	1294	4049	147	147,5	174
VS 30/29	RW6	37	50	2840,5	1294	4134,5	147	147,5	176
VS 30/30	RW6	37	50	2926	1294	4220	147	147,5	178,5
VS 30/31	RW8	45	60	3111	1230	4341	189	189	234,5
VS 30/32	RW8	45	60	3196,5	1230	4426,5	189	189	237,5
VS 30/33	RW8	45	60	3282	1230	4512	189	189	239,5
VS 30/34	RW8	45	60	3367,5	1230	4597,5	189	189	241,5
VS 30/35	RW8	45	60	3452,5	1230	4682,5	189	189	244

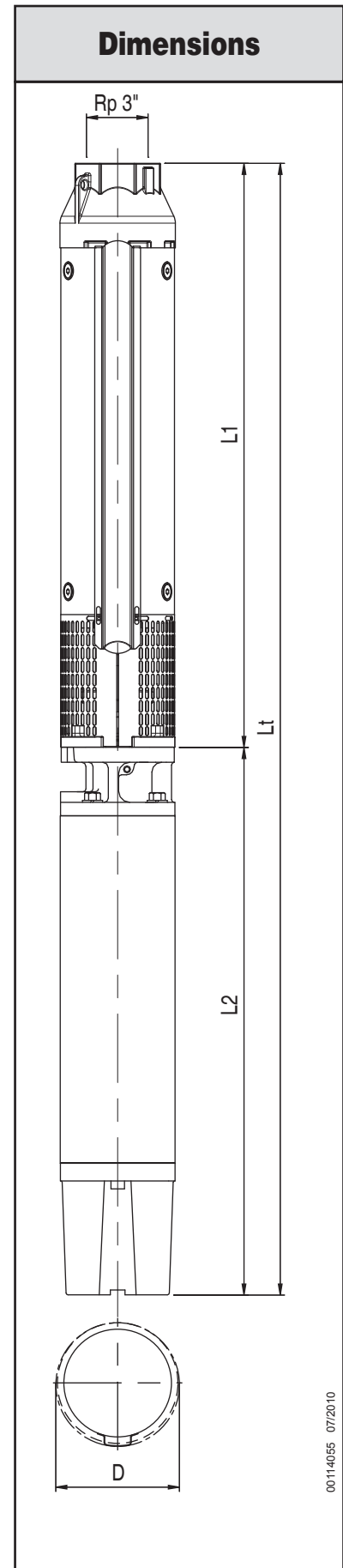

00114055 07/2010

Performance curves 50Hz

MEI ≥ 0,40

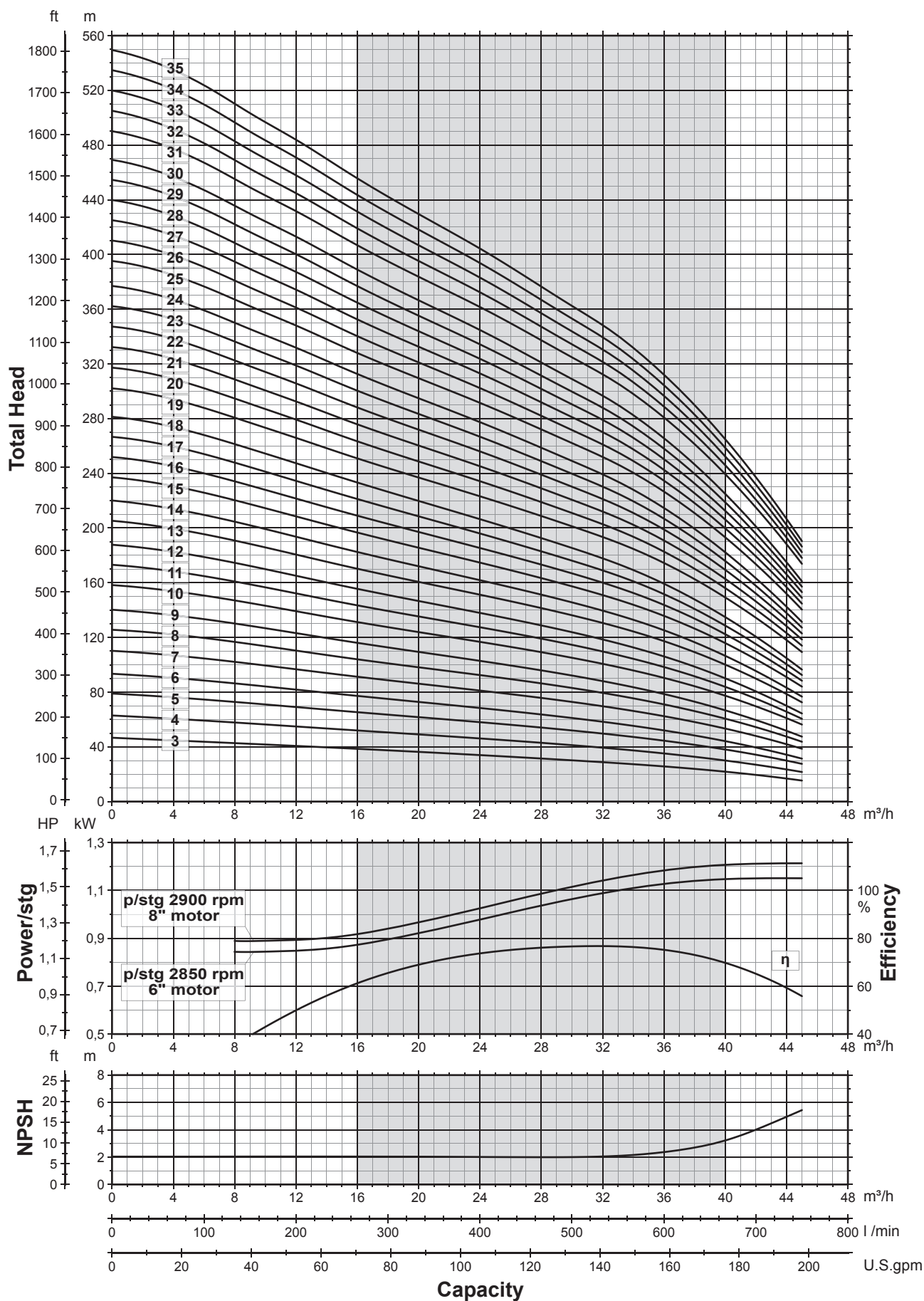

00110067 07/2010

Pumps with Encapsulated Motor

Pump model type	Motor			Dimensions					Weight Pump [Kg]
	Type	kW	HP	L1 [mm]	L2 [mm]	Lt [mm]	D		
							1 cable	2 cable	
VS 30/36	E6	45	60	3438	1574	5012	145	146,5	237
VS 30/37	E6	45	60	3523,5	1574	5097,5	145	146,5	239
VS 30/38	E8	55	75	3709	1204	4913	190,5	190,5	270,5
VS 30/39	E8	55	75	3794	1204	4998	190,5	190,5	272,5
VS 30/40	E8	55	75	3879,5	1204	5083,5	190,5	190,5	275
VS 30/41	E8	55	75	3965	1204	5169	190,5	190,5	276
VS 30/42	E8	55	75	4050,5	1204	5254,5	190,5	190,5	277
VS 30/43	E8	55	75	4135,5	1204	5339,5	190,5	190,5	278

Pumps with Rewindable Motor

Pump model type	Motor			Dimensions					Weight Pump [Kg]
	Type	kW	HP	L1 [mm]	L2 [mm]	Lt [mm]	D		
							1 cable	2 cable	
VS 30/36	RW8	45	60	3538	1230	4768	189	189	247
VS 30/37	RW8	45	60	3623,5	1230	4853,5	189	189	249
VS 30/38	RW8	55	75	3709	1340	5049	189	189	274,5
VS 30/39	RW8	55	75	3794	1340	5134	189	189	276,5
VS 30/40	RW8	55	75	3879,5	1340	5219,5	189	189	279
VS 30/41	RW8	55	75	3965	1340	5305	189	189	280
VS 30/42	RW8	55	75	4050,5	1340	5390,5	189	189	281
VS 30/43	RW8	55	75	4135,5	1340	5475,5	189	189	282

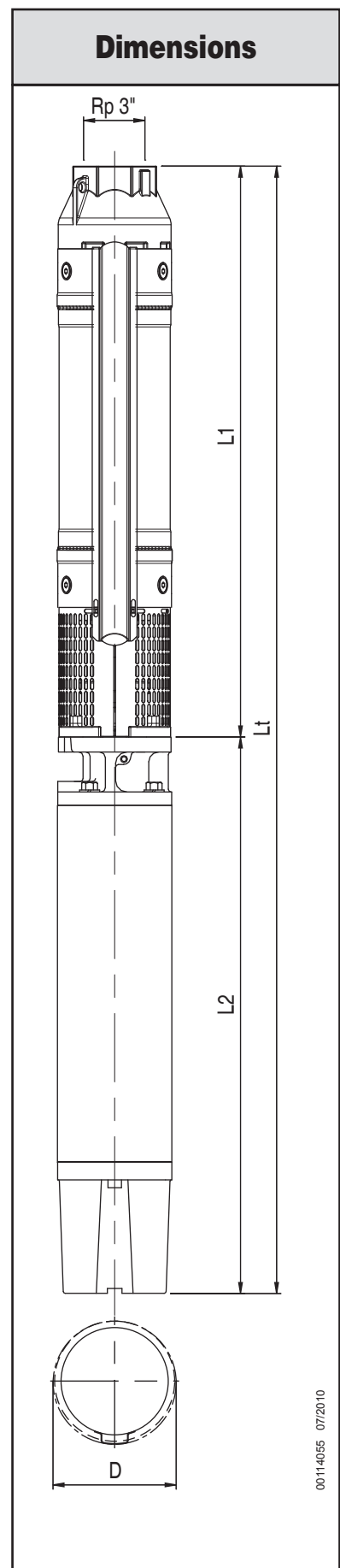

00114055 07/2010

Performance curves 50Hz

MEI ≥ 0,40

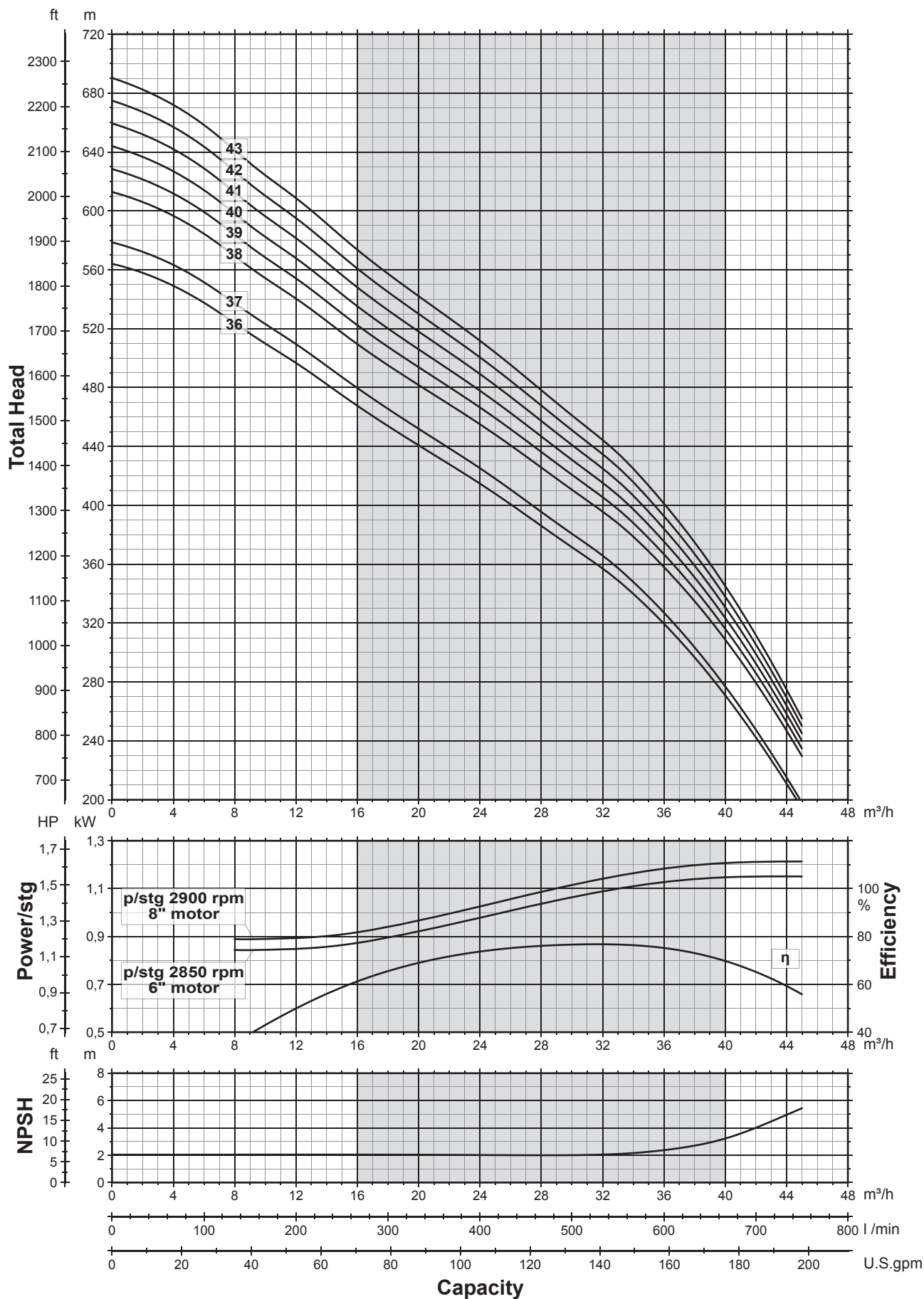

00110067 07/2010

Pumps with Encapsulated Motor

Pump model type	Motor			Dimensions					Weight Pump [Kg]
	Type	kW	HP	L1 [mm]	L2 [mm]	Lt [mm]	D		
							1 cable	2 cable	
VS 46/2	E4	3	4	593,5	477	1070,5	142,5	-	31
VS 46/3	E4	4	5,5	707,5	543	1250,5	142,5	-	36,5
VS 46/4	E4	5,5	7,5	821,5	652,5	1474	142,5	-	45,5
VS 46/5	E4	7,5	10	935,5	730,5	1666	142,5	-	52,5
VS 46/2	E6	4	5,5	591,5	581	1172,5	143	144,5	51
VS 46/3	E6	4	5,5	705,5	581	1286,5	143	144,5	53,5
VS 46/4	E6	5,5	7,5	819,5	614,5	1434	143	144,5	60
VS 46/5	E6	7,5	10	933,5	646	1579,5	143	144,5	66,5
VS 46/6	E6	9,3	12,5	1047	678,5	1725,5	143	144,5	71,5
VS 46/7	E6	9,3	12,5	1161	678,5	1839,5	143	144,5	74
VS 46/8	E6	11	15	1275	711	1986	143	144,5	80
VS 46/9	E6	15	20	1389	776	2165	143	144,5	88,5
VS 46/10	E6	15	20	1503	776	2279	143	144,5	91
VS 46/11	E6	15	20	1617	776	2393	143	144,5	93,5
VS 46/12	E6	18,5	25	1730,5	841,5	2572	143	144,5	103
VS 46/13	E6	18,5	25	1844,5	841,5	2686	143	144,5	105,5
VS 46/14	E6	18,5	25	1958,5	841,5	2800	143	144,5	108,5
VS 46/15	E6	22	30	2072,5	906,5	2979	143	144,5	117
VS 46/16	E6	22	30	2186	906,5	3092,5	143	144,5	119,5
VS 46/17	E6	22	30	2300	906,5	3206,5	143	144,5	122
VS 46/18	E6	30	40	2414	1036,5	3450,5	143	144,5	139,5
VS 46/19	E6	30	40	2527,5	1036,5	3564	143	144,5	142
VS 46/20	E6	30	40	2641,5	1036,5	3678	143	144,5	144,5
VS 46/21	E6	30	40	2755	1036,5	3791,5	143	144,5	147
VS 46/22	E6	30	40	2869	1036,5	3905,5	143	144,5	149,5
VS 46/23	E6	30	40	2983	1036,5	4019,5	143	144,5	152,5
VS 46/24	E6	37	50	3096,5	1421,5	4518	143	144,5	209
VS 46/25	E6	37	50	3210,5	1421,5	4632	143	144,5	211,5
VS 46/26	E6	37	50	3324	1421,5	4746,5	143	144,5	214

Pumps with Rewindable Motor

Pump model type	Motor			Dimensions					Weight Pump [Kg]
	Type	kW	HP	L1 [mm]	L2 [mm]	Lt [mm]	D		
							1 cable	2 cable	
VS 46/2	RW6	4	5,5	591,5	699	1290,5	147	147,5	61,5
VS 46/3	RW6	4	5,5	705,5	699	1404,5	147	147,5	64
VS 46/4	RW6	5,5	7,5	819,5	699	1518,5	147	147,5	67
VS 46/5	RW6	7,5	10	933,5	719	1652,5	147	147,5	71,5
VS 46/6	RW6	9,3	12,5	1047	749	1796	147	147,5	77
VS 46/7	RW6	9,3	12,5	1161	749	1910	147	147,5	79,5
VS 46/8	RW6	11	15	1275	779	2054	147	147,5	85
VS 46/9	RW6	13	17,5	1389	829	2218	147	147,5	93
VS 46/10	RW6	13	17,5	1503	829	2332	147	147,5	95,5
VS 46/11	RW6	15	20	1617	874	2491	147	147,5	103
VS 46/12	RW6	18,5	25	1730,5	919	2649,5	147	147,5	109,5
VS 46/13	RW6	18,5	25	1844,5	919	2763,5	147	147,5	112
VS 46/14	RW6	18,5	25	1958,5	919	2877,5	147	147,5	115
VS 46/15	RW6	22	30	2072,5	1009	3081,5	147	147,5	126,5
VS 46/16	RW6	22	30	2186	1009	3195	147	147,5	129
VS 46/17	RW6	22	30	2300	1009	3309	147	147,5	131,5
VS 46/18	RW6	26	35	2414	1114	3528	147	147,5	145,5
VS 46/19	RW6	26	35	2527,5	1114	3641,5	147	147,5	148
VS 46/20	RW6	30	40	2641,5	1214	3855,5	147	147,5	160,5
VS 46/21	RW6	30	40	2755	1214	3969	147	147,5	163
VS 46/22	RW6	30	40	2869	1214	4083	147	147,5	165,5
VS 46/23	RW6	30	40	2983	1214	4197	147	147,5	168,5
VS 46/24	RW6	37	50	3096,5	1294	4390,5	147	147,5	178
VS 46/25	RW6	37	50	3210,5	1294	4504,5	147	147,5	180,5
VS 46/26	RW6	37	50	3324	1294	4618	147	147,5	183

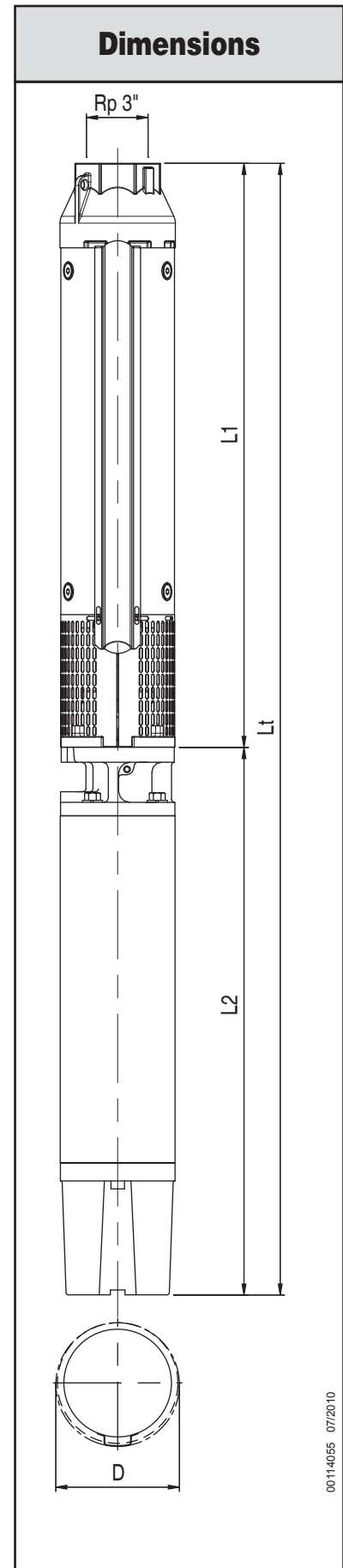

00114055 07/2010

Performance curves 50Hz

MEI ≥ 0,40

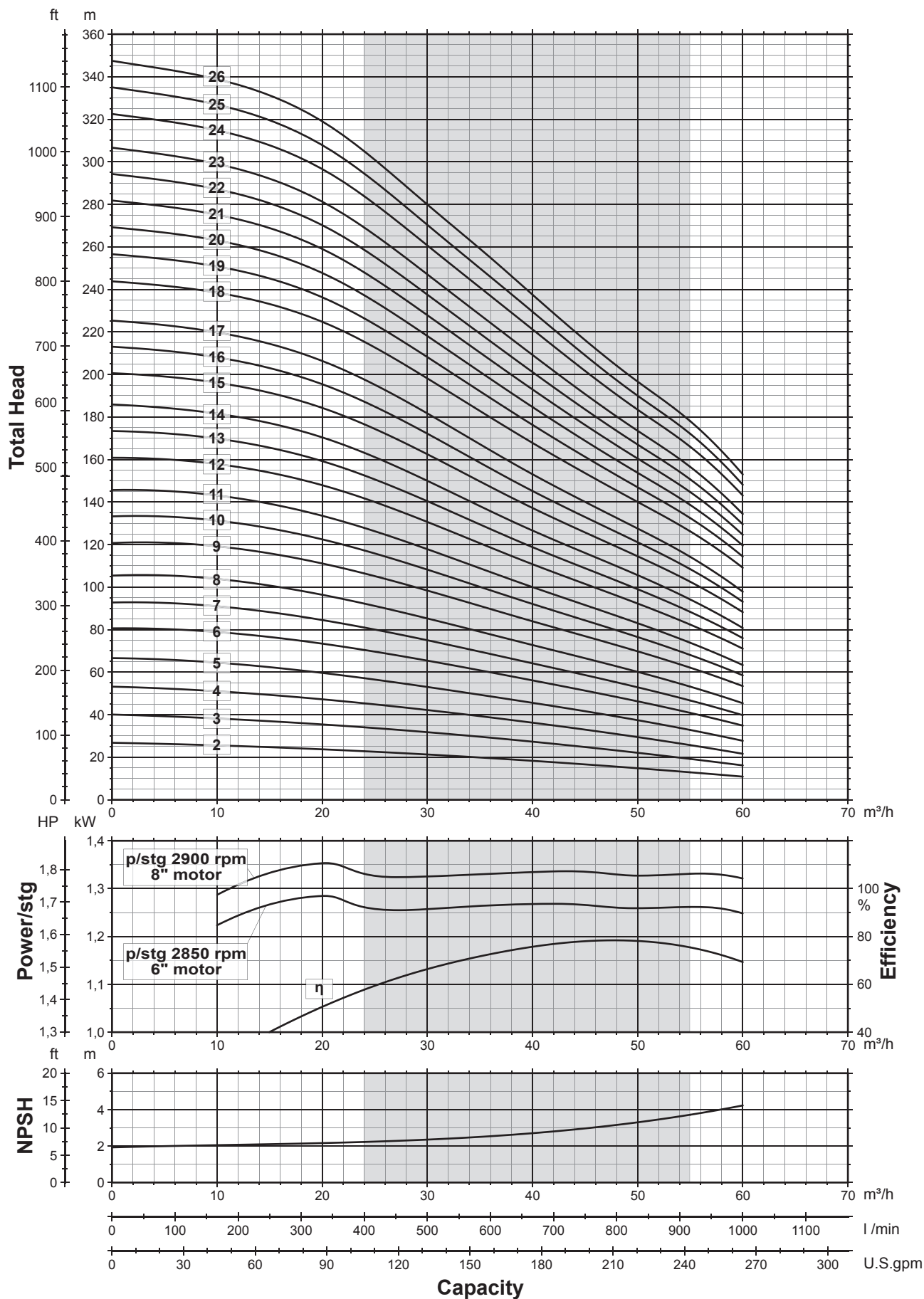

Pumps with Encapsulated Motor

Pump model type	Motor			Dimensions					Weight Pump [Kg]
	Type	kW	HP	L1 [mm]	L2 [mm]	Lt [mm]	D		
							1 cable	2 cable	
VS 46/27	E6	37	50	3438	1421,5	4859,5	145	146,5	217,5
VS 46/28	E6	37	50	3552	1421,5	4973,5	145	146,5	220
VS 46/29	E6	45	60	3665,5	1574	5239,5	145	146,5	236,5
VS 46/30	E6	45	60	3779,5	1574	5353,5	145	146,5	239
VS 46/31	E6	45	60	3893,5	1574	5467,5	145	146,5	242
VS 46/32	E6	45	60	4007	1574	5581	145	146,5	244,5
VS 46/33	E6	45	60	4121	1574	5695	145	146,5	247
VS 46/34	E8	55	75	4335	1204	5539	190,5	190,5	279
VS 46/35	E8	55	75	4449	1204	5653	190,5	190,5	281,5
VS 46/36	E8	55	75	4562,5	1204	5766,5	190,5	190,5	284,5
VS 46/37	E8	55	75	4676,5	1204	5880,5	190,5	190,5	287
VS 46/38	E8	55	75	4790,5	1204	5994,5	190,5	190,5	289,5
VS 46/39	E8	55	75	4904,5	1204	6108,5	190,5	190,5	292
VS 46/40	E8	55	75	5018,5	1204	6222,5	190,5	190,5	295

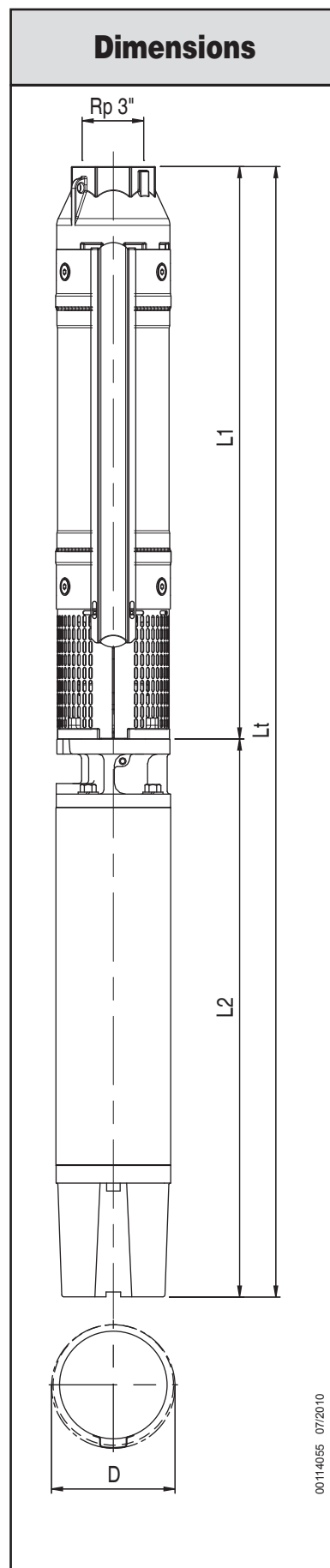

Pumps with Rewindable Motor

Pump model type	Motor			Dimensions					Weight Pump [Kg]
	Type	kW	HP	L1 [mm]	L2 [mm]	Lt [mm]	D		
							1 cable	2 cable	
VS 46/27	RW6	37	50	3438	1294	4732	149	149,5	186,5
VS 46/28	RW6	37	50	3552	1294	4846	149	149,5	189
VS 46/29	RW8	45	60	3765,5	1230	4995,5	189	189	246,5
VS 46/30	RW8	45	60	3879,5	1230	5109,5	189	189	249
VS 46/31	RW8	45	60	3993,5	1230	5223,5	189	189	252
VS 46/32	RW8	45	60	4107	1230	5337	189	189	254,5
VS 46/33	RW8	45	60	4221	1230	5451	189	189	257
VS 46/34	RW8	55	75	4335	1340	5675	189	189	283
VS 46/35	RW8	55	75	4449	1340	5789	189	189	285,5
VS 46/36	RW8	55	75	4562,5	1340	5902,5	189	189	288,5
VS 46/37	RW8	55	75	4676,5	1340	6016,5	189	189	291
VS 46/38	RW8	55	75	4790,5	1340	6130,5	189	189	293,5
VS 46/39	RW8	55	75	4904,5	1340	6244,5	189	189	296
VS 46/40	RW8	55	75	5018,5	1340	6358,5	189	189	299

Performance curves 50Hz

MEI ≥ 0,40

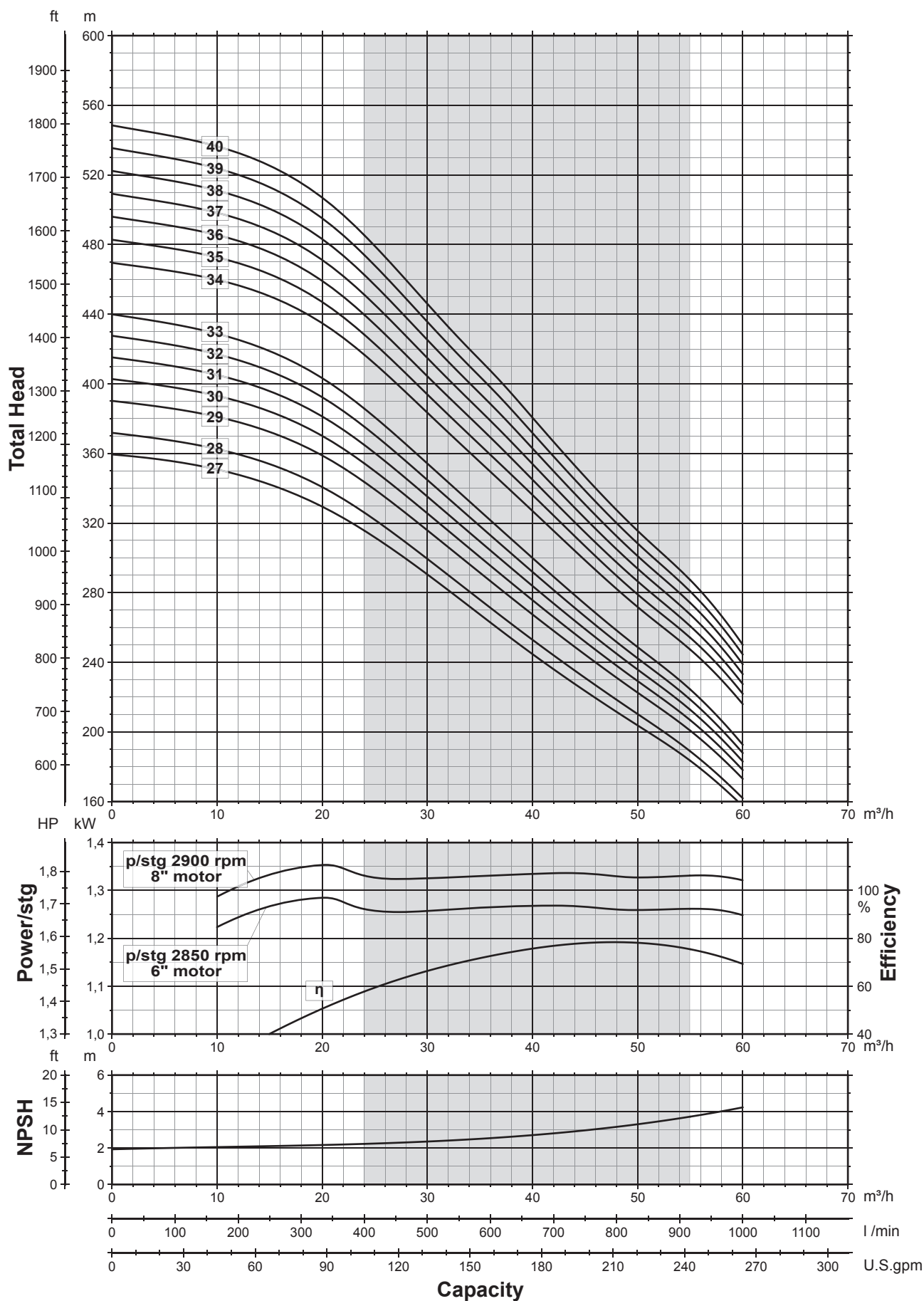

Pumps with Encapsulated Motor

Pump model type	Motor			Dimensions					Weight Pump [Kg]
	Type	kW	HP	L1 [mm]	L2 [mm]	Lt [mm]	D		
							1 cable	2 cable	
VS 65/2	E4	3,7	5	593,5	520	1113,5	142,5	-	33
VS 65/3	E4	5,5	7,5	707,5	652,5	1360	142,5	-	43
VS 65/4	E4	7,5	10	821,5	730,5	1552	142,5	-	49,5
VS 65/2	E6	4	5,5	591,5	581	1172,5	143	144,5	51
VS 65/3	E6	5,5	7,5	705,5	614,5	1320	143	144,5	57
VS 65/4	E6	7,5	10	819,5	646	1465,5	143	144,5	64
VS 65/5	E6	9,3	12,5	933,5	678,5	1612	143	144,5	69
VS 65/6	E6	11	15	1047	711	1758	143	144,5	75
VS 65/7	E6	15	20	1161	776	1937	143	144,5	83
VS 65/8	E6	15	20	1275	776	2051	143	144,5	86
VS 65/9	E6	15	20	1389	776	2165	143	144,5	88,5
VS 65/10	E6	18,5	25	1503	841,5	2344,5	143	144,5	98
VS 65/11	E6	18,5	25	1617	841,5	2458,5	143	144,5	100,5
VS 65/12	E6	22	30	1730,5	906,5	2637	143	144,5	109
VS 65/13	E6	22	30	1844,5	906,5	2751	143	144,5	112
VS 65/14	E6	30	40	1958,5	1036,5	2995	143	144,5	129
VS 65/15	E6	30	40	2072,5	1036,5	3109	143	144,5	131,5
VS 65/16	E6	30	40	2186	1036,5	3222,5	143	144,5	134
VS 65/17	E6	30	40	2300	1036,5	3336,5	143	144,5	137
VS 65/18	E6	37	50	2414	1421,5	3835,5	143	144,5	193,5
VS 65/19	E6	37	50	2527,5	1421,5	3949	143	144,5	196
VS 65/20	E6	37	50	2641,5	1421,5	4063	143	144,5	198,5
VS 65/21	E6	37	50	2755	1421,5	4176,5	143	144,5	201,5
VS 65/22	E6	45	60	2869	1574	4443	143	144,5	218
VS 65/23	E6	45	60	2983	1574	4557	143	144,5	220,5
VS 65/24	E6	45	60	3096,5	1574	4670,5	143	144,5	223
VS 65/25	E6	45	60	3210,5	1574	4784,5	143	144,5	225,5
VS 65/26	E6	45	60	3324	1574	4898	143	144,5	228,5

Pumps with Rewindable Motor

Pump model type	Motor			Dimensions					Weight Pump [Kg]
	Type	kW	HP	L1 [mm]	L2 [mm]	Lt [mm]	D		
							1 cable	2 cable	
VS 65/2	RW6	4	5,5	591,5	699	1290,5	147	147,5	61,5
VS 65/3	RW6	5,5	7,5	705,5	699	1404,5	147	147,5	64
VS 65/4	RW6	7,5	10	819,5	719	1538,5	147	147,5	69
VS 65/5	RW6	9,3	12,5	933,5	749	1682,5	147	147,5	74,5
VS 65/6	RW6	11	15	1047	779	1826	147	147,5	80
VS 65/7	RW6	13	17,5	1161	829	1990	147	147,5	87,5
VS 65/8	RW6	15	20	1275	874	2149	147	147,5	95,5
VS 65/9	RW6	15	20	1389	874	2263	147	147,5	98
VS 65/10	RW6	18,5	25	1503	919	2422	147	147,5	104,5
VS 65/11	RW6	18,5	25	1617	919	2536	147	147,5	107
VS 65/12	RW6	22	30	1730,5	1009	2739,5	147	147,5	118,5
VS 65/13	RW6	22	30	1844,5	1009	2853,5	147	147,5	121,5
VS 65/14	RW6	26	35	1958,5	1114	3072,5	147	147,5	135
VS 65/15	RW6	26	35	2072,5	1114	3186,5	147	147,5	137,5
VS 65/16	RW6	30	40	2186	1214	3400	147	147,5	150
VS 65/17	RW6	30	40	2300	1214	3514	147	147,5	153
VS 65/18	RW6	37	50	2414	1294	3708	147	147,5	162,5
VS 65/19	RW6	37	50	2527,5	1294	3821,5	147	147,5	165
VS 65/20	RW6	37	50	2641,5	1294	3935,5	147	147,5	167,5
VS 65/21	RW6	37	50	2755	1294	4049	147	147,5	170,5
VS 65/22	RW8	45	60	2969	1230	4199	189	189	224,5
VS 65/23	RW8	45	60	3083	1230	4313	189	189	227,5
VS 65/24	RW8	45	60	3196,5	1230	4426,5	189	189	230
VS 65/25	RW8	45	60	3310,5	1230	4540,5	189	189	232,5
VS 65/26	RW8	45	60	3424	1230	4654	189	189	235

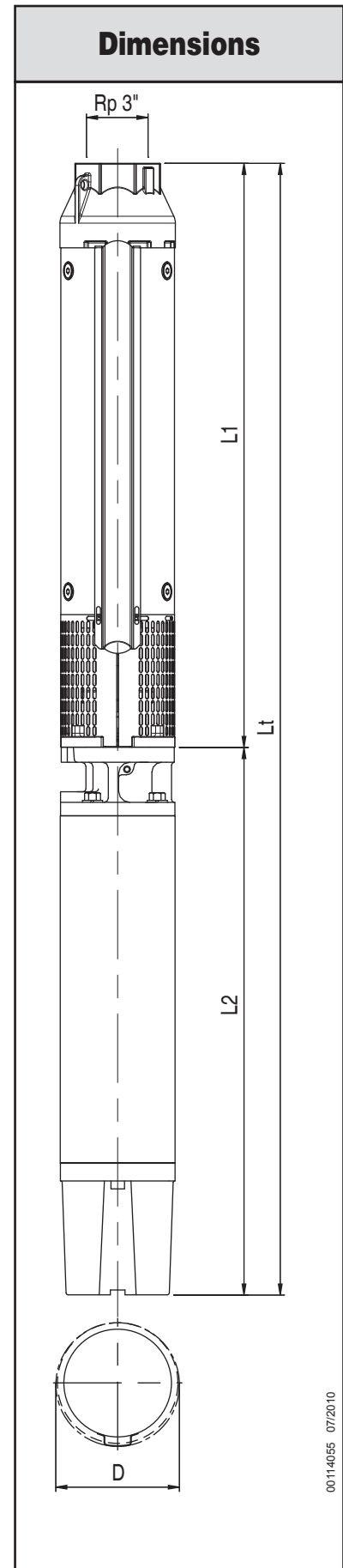

00114055 07/2010

Performance curves 50Hz

MEI ≥ 0,40

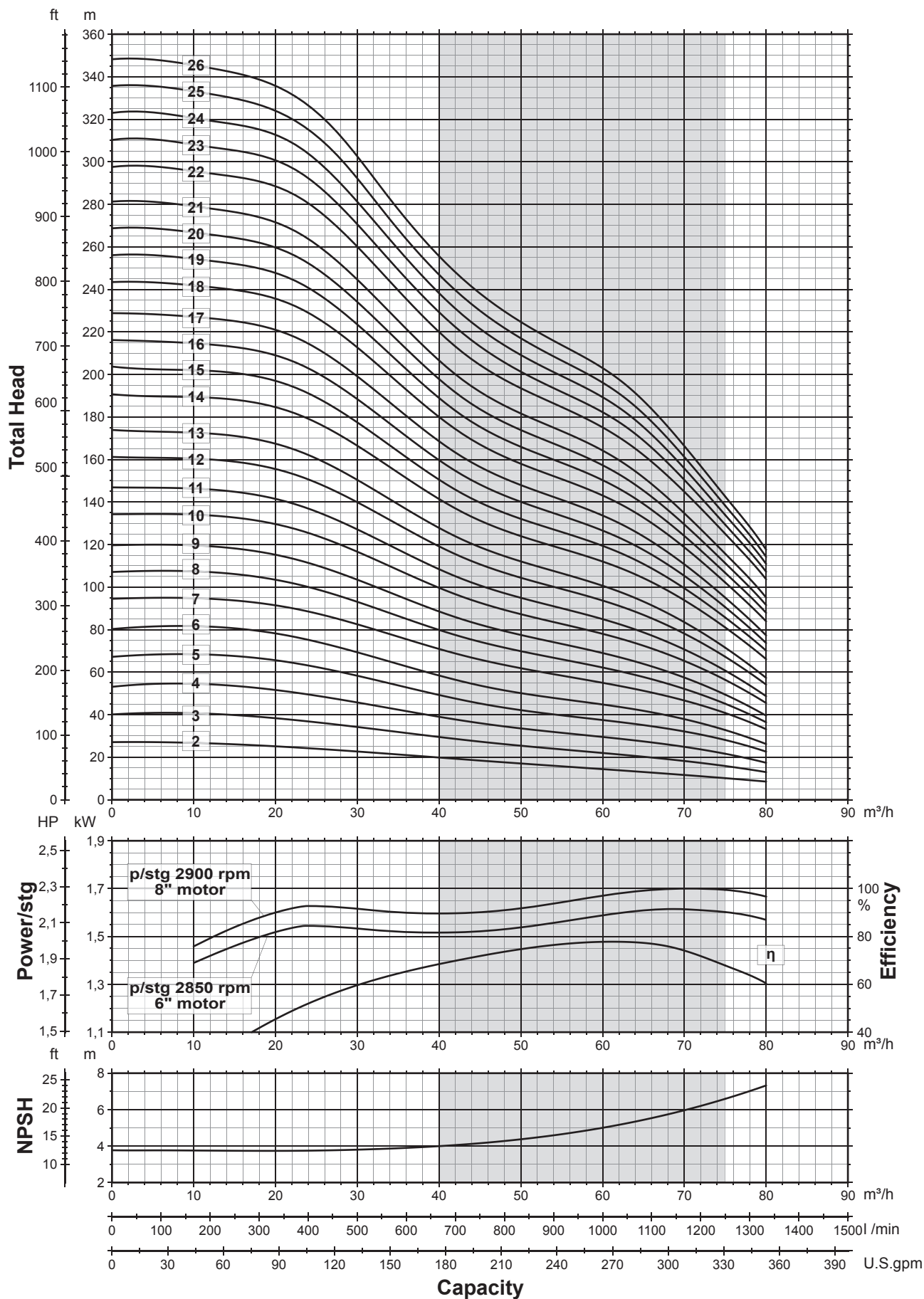

00110067 07/2010

Pumps with Encapsulated Motor

Pump model type	Motor			Dimensions					Weight Pump [Kg]
	Type	kW	HP	L1 [mm]	L2 [mm]	Lt [mm]	D		
							1 cable	2 cable	
VS 65/27	E8	55	75	3538	1204	4742	190,5	190,5	261
VS 65/28	E8	55	75	3652	1204	4856	190,5	190,5	263,5
VS 65/29	E8	55	75	3765,5	1204	4969,5	190,5	190,5	266
VS 65/30	E8	55	75	3879,5	1204	5083,5	190,5	190,5	268,5
VS 65/31	E8	55	75	3993,5	1204	5197,5	190,5	190,5	271,5

Pumps with Rewindable Motor

Pump model type	Motor			Dimensions					Weight Pump [Kg]
	Type	kW	HP	L1 [mm]	L2 [mm]	Lt [mm]	D		
							1 cable	2 cable	
VS 65/27	RW8	55	75	3538	1340	4878	189	189	265
VS 65/28	RW8	55	75	3652	1340	4992	189	189	267,5
VS 65/29	RW8	55	75	3765,5	1340	5105,5	189	189	270
VS 65/30	RW8	55	75	3879,5	1340	5219,5	189	189	272,5
VS 65/31	RW8	55	75	3993,5	1340	5333,5	189	189	275,5

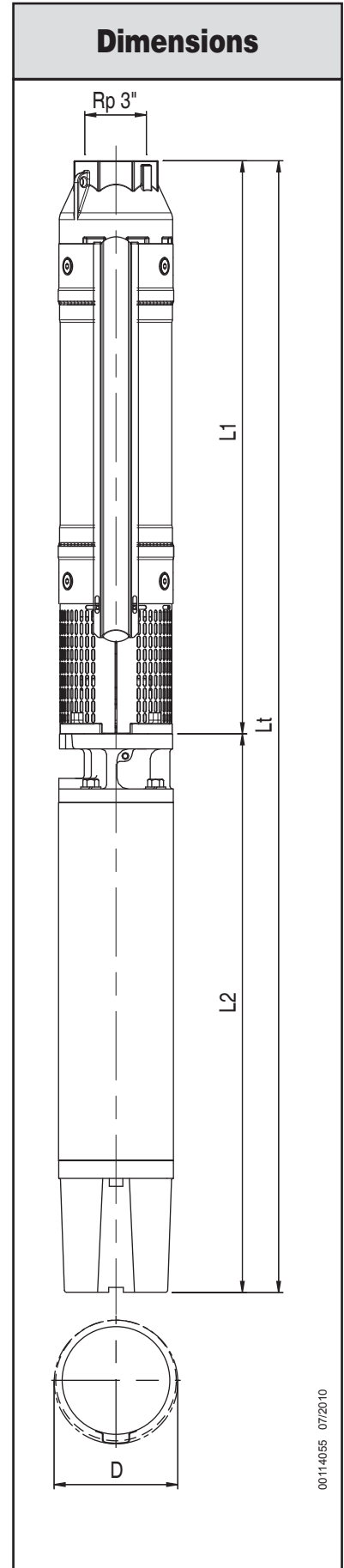

00114055 07/2010

Performance curves 50Hz

MEI ≥ 0,40

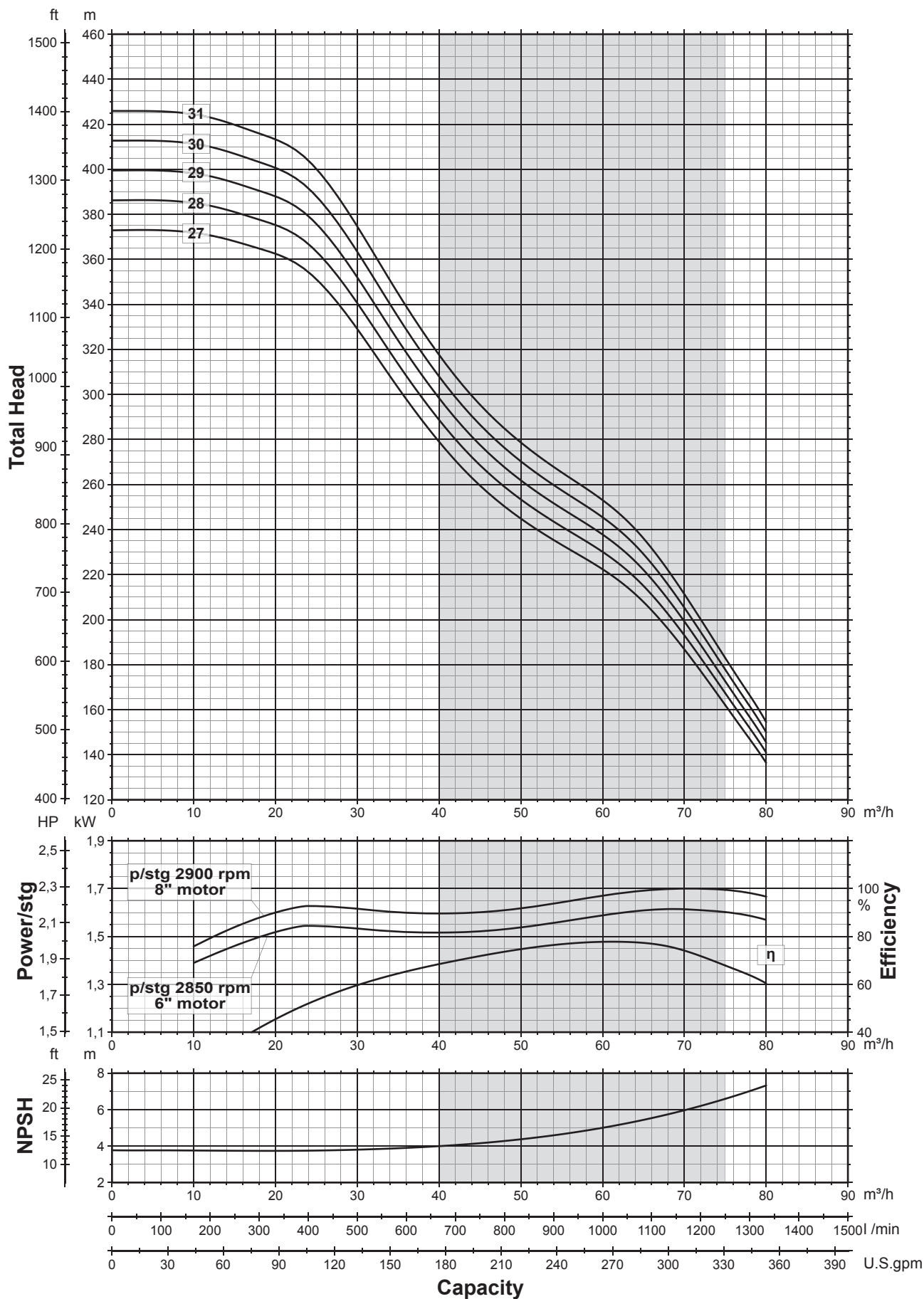

Section and List of Main Components

VS 14

VS 19

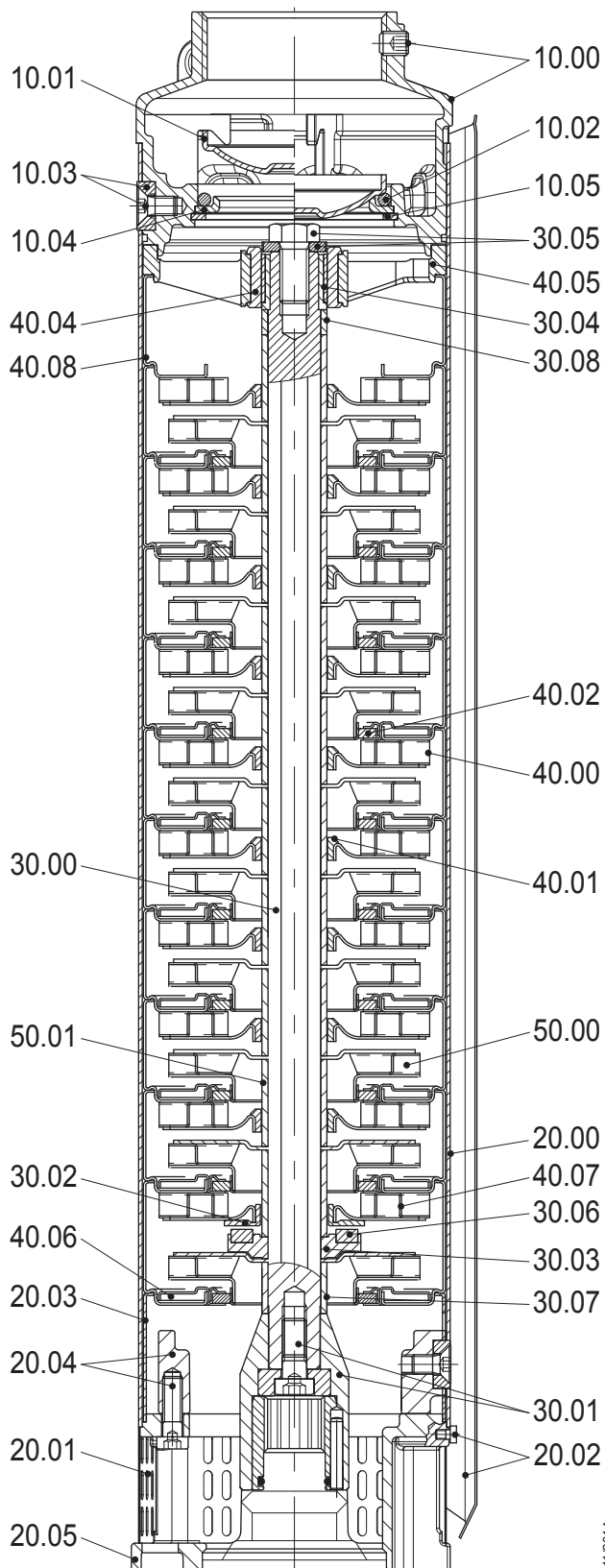

00114056 11/2014

Ref. N.	Description
10 00	Discharge head and screw
10 01	Valve
10 02	O-ring
10 03	Screws and outer case locking nuts
10 04	Valve support
10 05	Seeger ring
20 00	Outer case
20 01	Suction strainer
20 02	Cable guard and screws
20 03	Initial spacer
20 04	Flange and bolts
20 05	Motor adapter
20 06	4" motor flange / coupling adapter
30 00	Pump shaft
30 01	Coupling
30 02	Upper up-thrust washer
30 03	Lower up-thrust washer
30 04	Upper journal sleeve
30 05	Screw and washer
30 06	Up-thrust ring
30 07	Lower spacer
30 08	Upper spacer
40 00	Diffusers
40 01	Secondary bearing bush
40 02	Floating neck ring
40 04	Bearing bush
40 05	Upper bearing guide
40 06	First diffuser
40 07	Diffuser with upper up-thrust washer
40 08	Last diffuser
50 00	Impeller
50 01	Impeller spacer
50 05	Wear ring

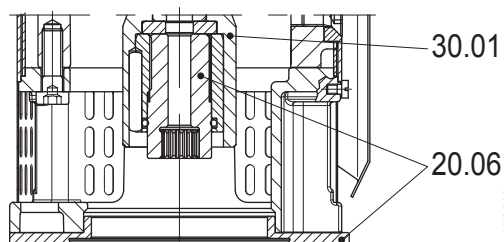

00114056 11/2010

Section and List of Main Components

VS 30

VS 46

VS 65

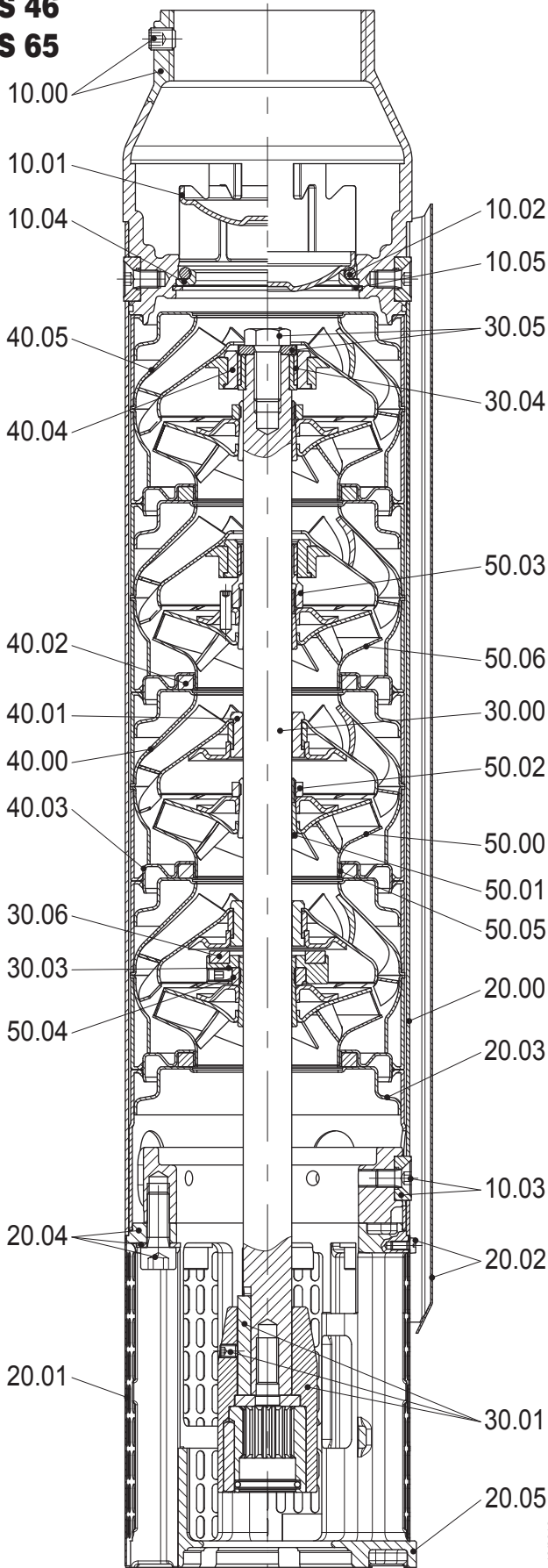

Ref. N.	Description
1000	Discharge head and screw
1001	Valve
1002	O-ring
1003	Screws and outer case locking nuts
1004	Valve support
1005	Seeger ring
2000	Outer case
2001	Suction strainer
2002	Cable guard and screws
2003	Initial spacer
2004	Flange and bolts
2005	Motor adapter
2006	4" motor flange / coupling adapter
2007	8" motor adapter / bolts and washer
3000	Pump shaft
3001	Coupling
3003	Lower up-thrust washer
3004	Upper journal sleeve
3005	Screw and washer
3006	Up-thrust ring
4000	Diffusers
4001	Secondary bearing bush
4002	Floating neck ring
4003	Flange clamping neck ring
4004	Bearing bush
4005	Last / intermediate diffuser
5000	Impeller
5001	Split cone
5002	Split cone nut
5003	Intermediate split cone nut
5004	Up-thrust split cone nut
5005	Wear ring
5006	Intermediate impeller with screw

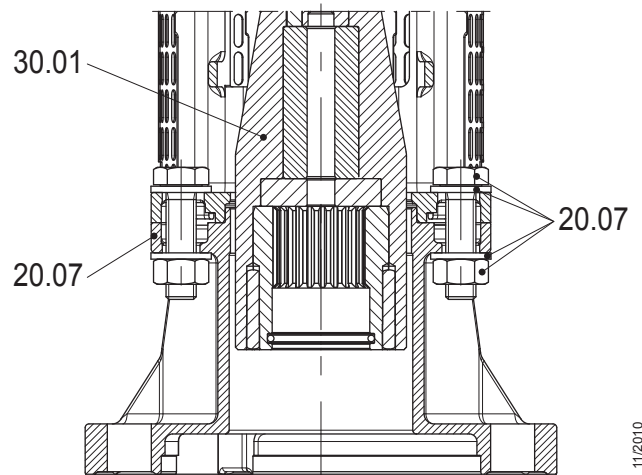
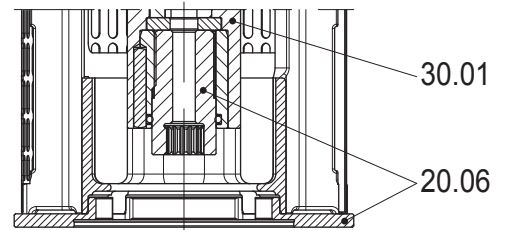

00114056 12/2012

00114056 11/2010

Motor Adapter VS 14 / 19

4" Motor Adapter

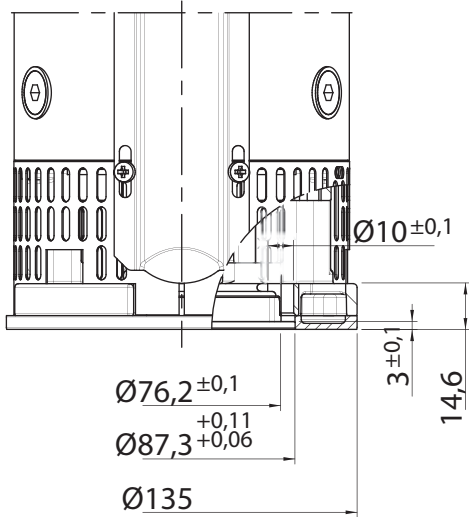

00114064 11/2010

6" Motor Adapter

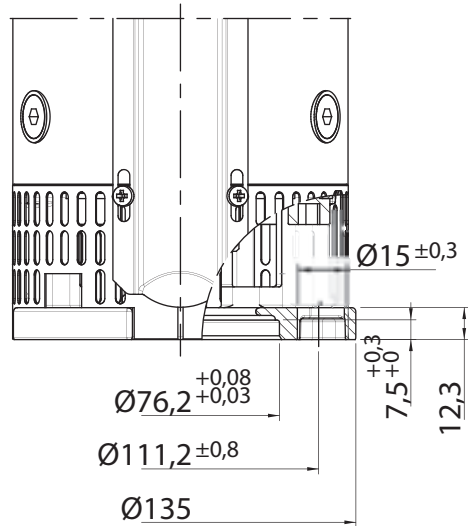

00114064 11/2010

Motor Adapter VS 30 / 46 / 65

4" Motor Adapter

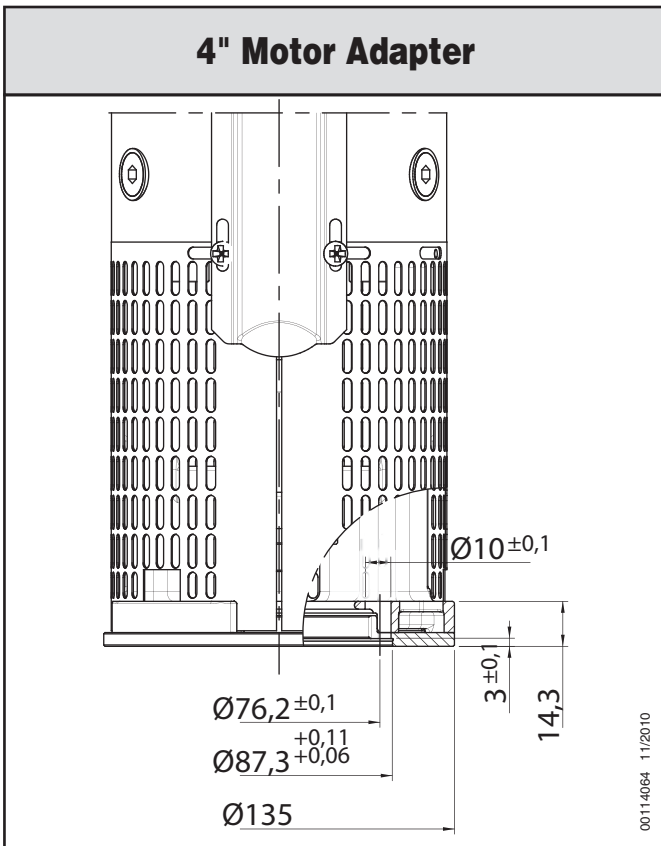

6" Motor Adapter

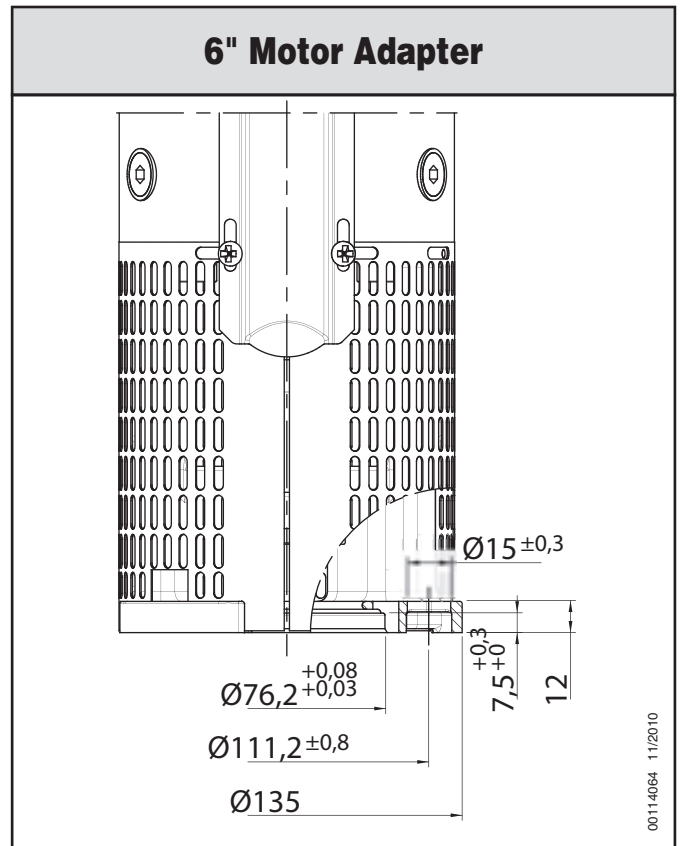

8" Motor Adapter

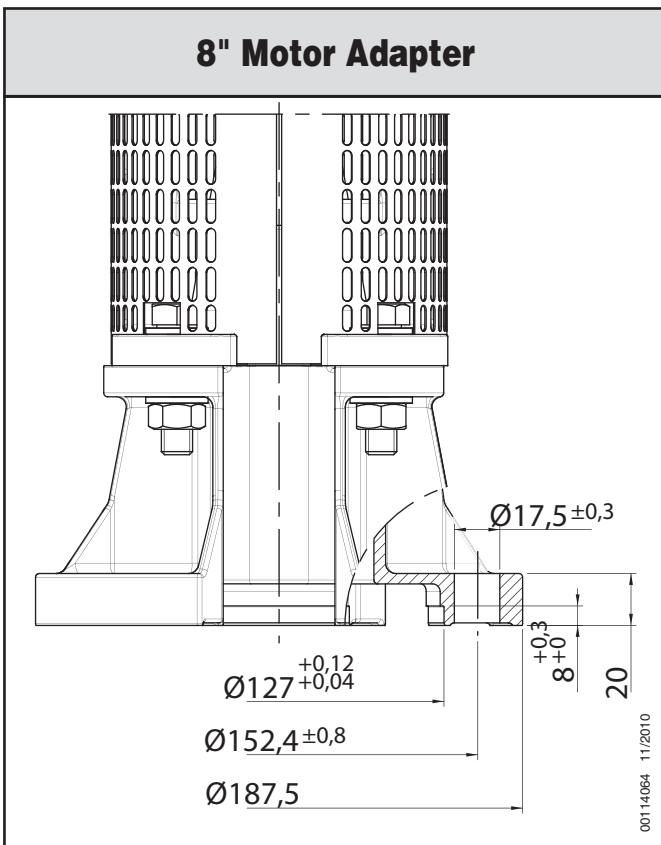

VS Series Stainless Steel Submersible Pumps for 8" deep wells and larger

Characteristics and Hydraulic Performances

50 Hz

APPLICATIONS

- Municipal water works
- Water distribution and pressure boosting
- Irrigation and sprinkler systems, water treatment plants, filtration and reverse osmosis
- Industrial cooling and processing
- Mining industry, drainage and dewatering
- Fountains
- Fire-fighting equipment

FEATURES

- Stainless steel components for durability and robustness, to increase run-time and trouble-free operation. Many design technical features make this pump range very compact and extremely reliable
- Three-dimensional twisted blades of the impeller and diffuser design to enhance efficiency and to reduce energy consumption
- External stainless steel sleeve to improve stiffness and assure permanent alignment of all the components
- Motor adapter and discharge head may be removed without disturbing the impeller / diffuser stack
- Built-in check valve and over size pump shaft
- Very compact and extremely reliable to resist to the most complex and severe conditions
- Easy maintenance without the need of special tools

SPECIFICATIONS

- Capacities up to 120 m³/h at 50Hz
- 50 Bar (500 m) at 50Hz
- Maximum allowable amount of sand 100 gr/m³
- Water temperature range: from -5° C to 60°C
- Rotation: counter clockwise when looking into the discharge
- Motor adapter in compliance with NEMA standard
- Pump can work continuously in vertical or horizontal position
- Motors: see section Submersible Motors Product Overview

AVAILABLE OPTIONS

- 316 Stainless steel (N) version (DIN/EN 1.4401)
- Double cable guard
- Rp 4" outlet adapter
- Rp 6" outlet adapter

PUMP IDENTIFICATION CODE

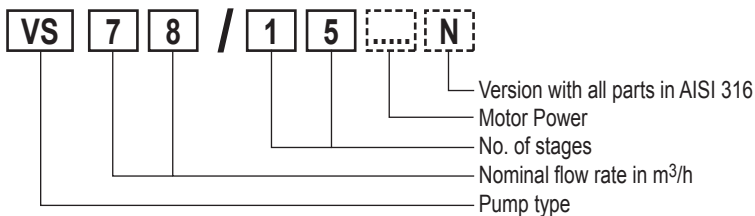

00117017 09/2009

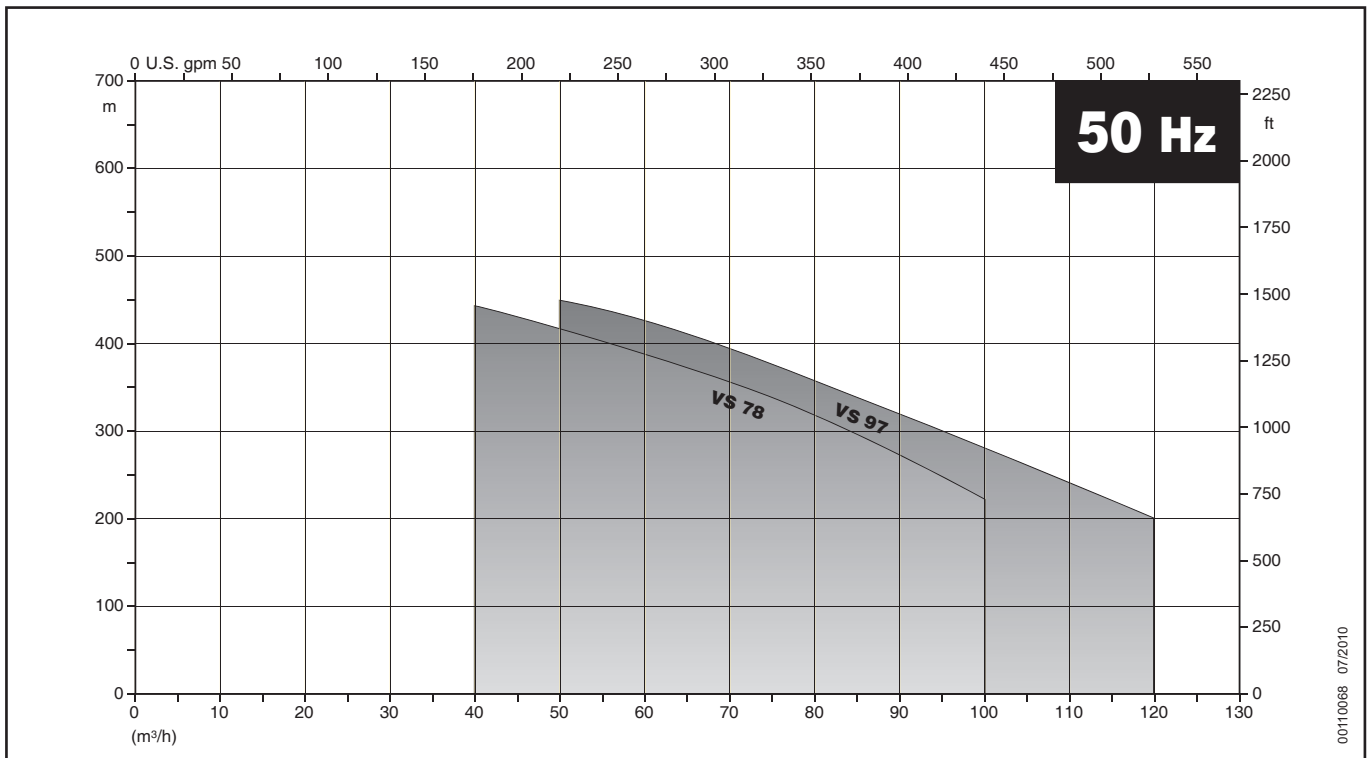

00110068 07/2010

MATERIAL IN CONTACT WITH THE LIQUID

Pos.	PARTS DESCRIPTIONS	Type	MATERIAL			
			Standard version		N version	
			AISI	DIN / EN	AISI	DIN / EN
10.00	Discharge head	Stainless steel	304	1.4301	316	1.4401
10.01	Valve	Stainless steel	316	1.4401	316	1.4401
10.02	Sealing O-ring	Nitrile rubber (NBR)	-	-	-	-
10.03	Outer case locking nuts	Stainless steel	316	1.4401	316	1.4401
10.04	Valve support	Stainless steel and PTFE	316	1.4401	316	1.4401
10.05	Seeger ring	Stainless steel	316	1.4401	316	1.4401
10.06	Spring	Stainless steel	316	1.4401	316	1.4401
20.00	Outer case	Stainless steel	304	1.4301	316	1.4401
20.01	Suction strainer	Stainless steel	316	1.4401	316	1.4401
20.02	Cable guard	Stainless steel	316	1.4401	316	1.4401
20.03	Initial spacer	Stainless steel	316	1.4401	316	1.4401
20.04	Flange and screws	Stainless steel	304	1.4301	316	1.4401
20.05	Motor adapter	Stainless steel	304	1.4301	316	1.4401
30.00	Pump shaft	Stainless steel	329	1.4460	329	1.4460
30.01	Coupling	Stainless steel	431/329	1.4057/1.4460	316/329	1.4401/1.4460
30.02	Upper up-thrust washer	Stainless steel	329	1.4460	329	1.4460
30.03	Lower up-thrust washer	Stainless steel	329	1.4460	329	1.4460
30.04	Upper journal sleeve ⁽¹⁾	Stainless steel with ceramic casting	-	-	-	-
30.05	Screw and washer	Stainless steel	316	1.4401	316	1.4401
30.06	Up-thrust ring	PTFE + Graphite	-	-	-	-
40.00	Diffuser	Stainless steel	304	1.4301	316	1.4401
40.01	Secondary bearing bush	Nitrile rubber (NBR)	-	-	-	-
40.02	Floating neck ring	PTFE	-	-	-	-
40.03	Flange clamping neck ring	Stainless steel	316	1.4401	316	1.4401
50.00	Impeller	Stainless steel	316	1.4401	316	1.4401
50.01	Split cone	Stainless steel	316	1.4401	316	1.4401
50.02	Split cone nut	Stainless steel	316	1.4401	316	1.4401

1) only for types with more than 8 stages

VS78**TABLE OF HYDRAULIC PERFORMANCES AT 50Hz**

PUMP TYPE	RATED POWER		Q = DELIVERY											
	kW	HP	m ³ /h	0	30	40	50	60	70	80	90	100	110	120
			l/min	0	500	666	833	1000	1166	1333	1500	1666	1833	2000
H = TOTAL HEAD METERS COLUMN OF WATER [m]														
VS 78/2	7,5	10		40	38	35	32	30	29	24	20	18		
VS 78/3	11	15		60	55	51	49	45	41	36	30	24		
VS 78/4	15	20		80	74	70	65	60	55	49	41	32		
VS 78/5	18,5	25		99	92	88	81	75	69	60	51	41		
VS 78/6	22	30		119	110	104	98	89	81	71	60	49		
VS 78/7	30	40		139	130	122	114	105	96	85	72	58		
VS 78/8	30	40		159	149	140	131	120	110	98	82	67		
VS 78/9	30	40		180	168	158	147	135	123	110	92	73		
VS 78/10	37	50		197	183	172	160	148	134	119	100	79		
VS 78/11	37	50		216	202	190	176	162	148	130	110	87		
VS 78/12	45	60		248	232	219	205	189	172	153	131	106		
VS 78/13	55	75		269	252	237	221	205	188	168	142	115		
VS 78/14	55	75		289	271	256	239	220	201	180	153	123		
VS 78/15	55	75		309	290	274	255	235	215	192	165	132		
VS 78/16	75	100		332	311	294	275	252	231	208	177	143		
VS 78/17	75	100		352	330	312	291	269	246	220	188	151		
VS 78/18	75	100		373	350	330	309	284	260	232	198	161		
VS 78/19	75	100		394	370	348	325	300	275	245	210	170		
VS 78/20	75	100		415	389	368	343	316	290	259	220	179		
VS 78/21	75	100		436	409	385	360	331	304	271	231	189		
VS 78/22	93	125		457	428	404	378	347	320	284	243	198		
VS 78/23	93	125		478	446	421	394	362	332	297	254	207		
VS 78/24	93	125		498	467	440	411	379	348	310	265	216		

VS97**TABLE OF HYDRAULIC PERFORMANCES AT 50Hz**

PUMP TYPE	RATED POWER		Q = DELIVERY											
	kW	HP	m ³ /h	0	30	40	50	60	70	80	90	100	110	120
			l/min	0	500	666	833	1000	1166	1333	1500	1666	1833	2000
H = TOTAL HEAD METERS COLUMN OF WATER [m]														
VS 97/2	9,3	12,5		42	41	39	36	32	30	29	26	22	19	15
VS 97/3	15	20		63	60	58	53	49	45	42	39	33	29	21
VS 97/4	18,5	25		84	81	77	71	65	60	57	51	45	38	30
VS 97/5	22	30		104	101	95	88	80	74	69,5	62	55	46	37
VS 97/6	30	40		127	122	115	107	98	90	84	77	68	57	46
VS 97/7	30	40		148	143	135	123	115	106	99	90	79	68	52
VS 97/8	37	50		168	160	151	140	130	120	110	100	88,5	74	59
VS 97/9	37	50		188	180	170	158	147	133	124	113	99	83	66
VS 97/10	45	60		219	211	200	185	172	159	148	137	120	103	82
VS 97/11	55	75		241	232	220	204	189	175	162	149	132	113	91
VS 97/12	55	75		262	253	240	221	207	191	178	162	143	123	99
VS 97/13	55	75		284	275	260	241	223	207	191	177	155	132	108
VS 97/14	75	100		309	297	282	261	242	226	209	191	169	145	121
VS 97/15	75	100		330	319	303	280	260	240	222	205	181	155	130
VS 97/16	75	100		352	340	322	299	279	258	238	220	194	165	139
VS 97/17	75	100		373	361	342	319	294	272	252	232	207	176	147
VS 97/18	93	125		398	382	363	337	313	289	268	247	219	188	155
VS 97/19	93	125		419	403	382	354	330	305	282	260	230	197	164
VS 97/20	93	125		440	423	404	372	347	320	298	273	241	208	171
VS 97/21	93	125		462	445	422	391	363	337	312	289	255	219	171
VS 97/22	110	150		484	466	442	410	381	353	328	301	267	229	190
VS 97/23	110	150		507	487	463	430	399	370	341	315	279	239	199

VS Series Stainless Steel Submersible Pumps for 8" deep wells and larger

Technical Data and Performance Curves

50 Hz

Pumps with Encapsulated Motor

Pump model type	Motor			Dimensions					Weight Pump [Kg]
	Type	kW	HP	L1 [mm]	L2 [mm]	Lt [mm]	D		
							1 cable	2 cable	
VS 78/2	E6	7,5	10	644	646	1290	188	194	77
VS 78/3	E6	11	15	770	711	1481	188	194	87
VS 78/4	E6	15	20	896	776	1672	188	194	57
VS 78/5	E6	18,5	25	1022	841,5	1863,5	188	194	109
VS 78/6	E6	22	30	1148	906,5	2054,5	188	194	120
VS 78/7	E6	30	40	1274	1036,5	2310,5	188	194	140
VS 78/8	E6	30	40	1400	1036,5	2436,5	188	194	145
VS 78/9	E6	30	40	1526	1036,5	2562,5	188	194	150
VS 78/10	E6	37	50	1652	1405	3057	188	194	206
VS 78/11	E6	37	50	1778	1405	3183	188	194	211
VS 78/12	E8	45	60	1909	1077	2986	200	202	254
VS 78/13	E8	55	75	2035	1394	3429	200	202	259
VS 78/14	E8	55	75	2161	1394	3555	200	202	294
VS 78/15	E8	55	75	2287	1394	3681	200	202	299
VS 78/16	E8	75	100	2413	1496	3909	200	202	342
VS 78/17	E8	75	100	2539	1496	4035	200	202	347
VS 78/18	E8	75	100	2665	1496	4161	200	202	352
VS 78/19	E8	75	100	2791	1496	4287	200	202	357
VS 78/20	E8	75	100	2917	1496	4413	200	202	361
VS 78/21	E8	75	100	3043	1496	4539	200	202	366
VS 78/22	E8	93	125	3169	1748	4917	200	202	449
VS 78/23	E8	93	125	3295	1748	5043	200	202	454
VS 78/24	E8	93	125	3421	1748	5169	200	202	459

Dimensions

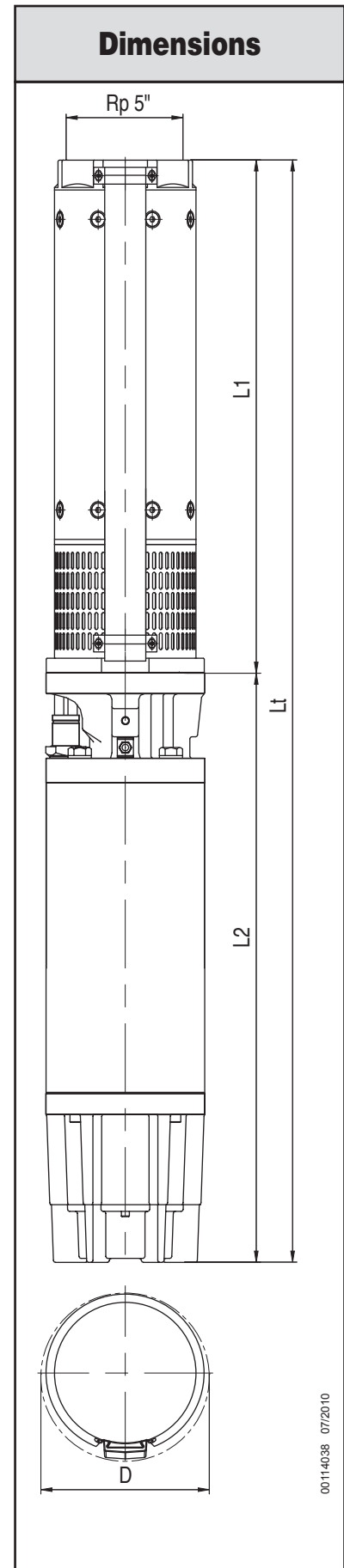

Pumps with Rewindable Motor

Pump model type	Motor			Dimensions					Weight Pump [Kg]
	Type	kW	HP	L1 [mm]	L2 [mm]	Lt [mm]	D		
							1 cable	2 cable	
VS 78/2	6RW	7,5	10	644	719	1363	188	194	82
VS 78/3	6RW	11	15	770	779	1549	188	194	92
VS 78/4	6RW	15	20	896	874	1770	188	194	66
VS 78/5	6RW	18,5	25	1022	919	1941	188	194	116
VS 78/6	6RW	22	30	1148	1009	2157	188	194	130
VS 78/7	6RW	26	35	1274	1114	2388	188	194	146
VS 78/8	6RW	30	40	1400	1214	2614	188	194	161
VS 78/9	6RW	30	40	1526	1214	2740	188	194	166
VS 78/10	6RW	37	50	1652	1294	2946	188	194	178
VS 78/11	6RW	37	50	1778	1294	3072	188	194	183
VS 78/12	8RW	45	60	1909	1230	3139	197	199.5	238
VS 78/13	8RW	52	70	2035	1340	3375	197	199.5	266
VS 78/14	8RW	52	70	2161	1340	3501	197	199.5	271
VS 78/15	8RW	55	75	2287	1340	3627	197	199.5	276
VS 78/16	8RW	60	80	2413	1470	3883	197	199.5	300
VS 78/17	8RW	67	90	2539	1470	4009	197	199.5	305
VS 78/18	8RW	67	90	2665	1470	4135	197	199.5	310
VS 78/19	8RW	75	100	2791	1560	4351	197	199.5	332
VS 78/20	8RW	75	100	2917	1560	4477	197	199.5	336
VS 78/21	8RW	75	100	3043	1560	4603	197	199.5	341
VS 78/22	8RW	83	110	3169	1560	4729	197	199.5	378
VS 78/23	8RW	83	110	3295	1560	4855	197	199.5	383
VS 78/24	8RW	93	125	3421	1740	5161	197	199.5	388

00114038 07/2010

Performance curves 50Hz

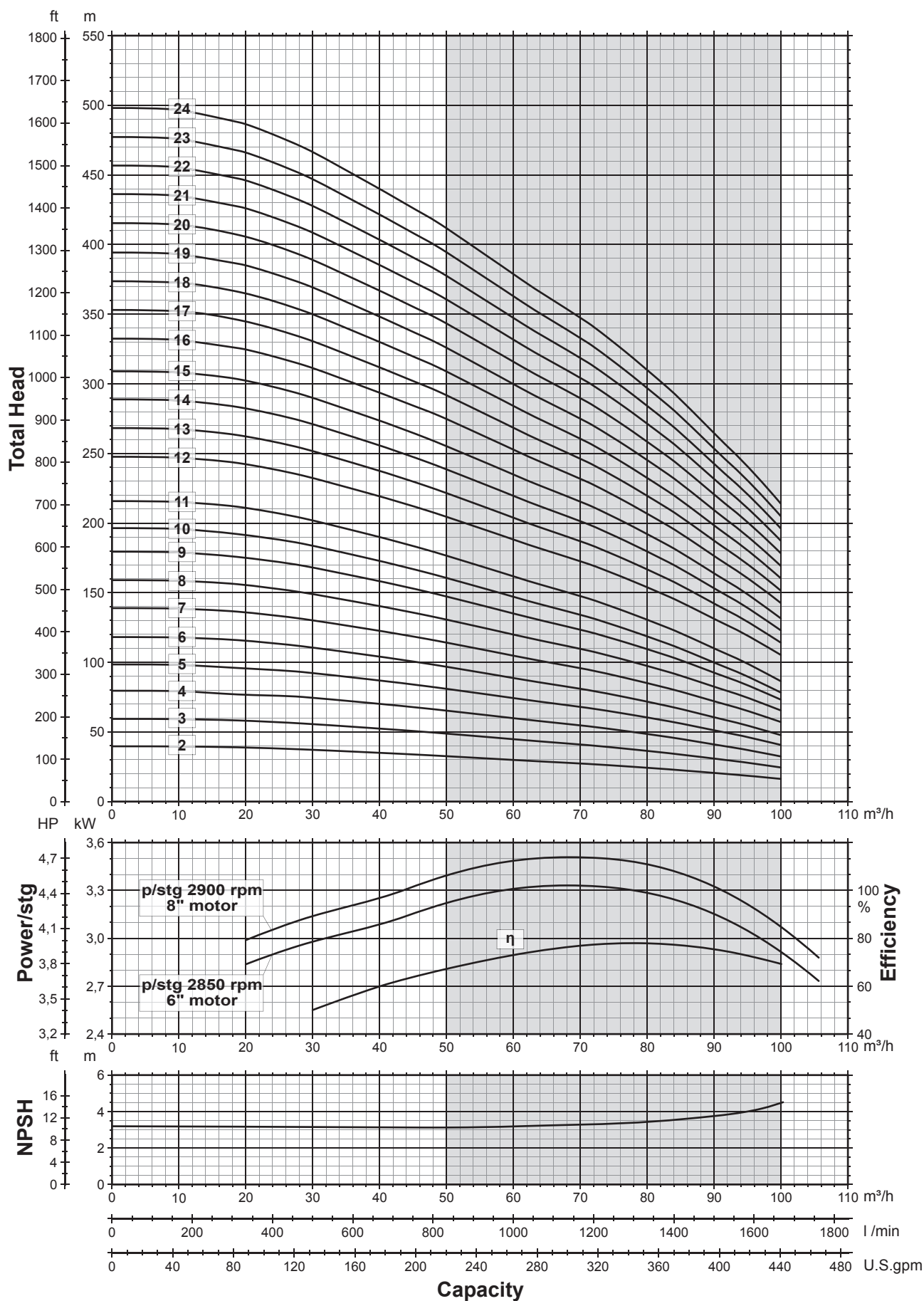

00110070 07/2010

Pumps with Encapsulated Motor

Pump model type	Motor			Dimensions					Weight Pump [Kg]
	Type	kW	HP	L1 [mm]	L2 [mm]	Lt [mm]	D		
							1 cable	2 cable	
VS 97/2	E6	9,3	12,5	644	678,5	1322,5	188	194	79
VS 97/3	E6	15	20	770	776	1546	188	194	93
VS 97/4	E6	18,5	25	896	841,5	1737,5	188	194	105
VS 97/5	E6	22	30	1022	906,5	1928,5	188	194	115,5
VS 97/6	E6	30	40	1148	1036,5	2184,5	188	194	135
VS 97/7	E6	30	40	1274	1036,5	2310,5	188	194	140
VS 97/8	E6	37	50	1400	1405	2805	188	194	196
VS 97/9	E6	37	50	1526	1405	2931	188	194	201
VS 97/10	E8	45	60	1657	1077	2734	200	202	244
VS 97/11	E8	55	75	1783	1394	3177	200	202	279
VS 97/12	E8	55	75	1909	1394	3303	200	202	284
VS 97/13	E8	55	75	2035	1394	3429	200	202	289
VS 97/14	E8	75	100	2161	1496	3657	200	202	332
VS 97/15	E8	75	100	2287	1496	3783	200	202	337
VS 97/16	E8	75	100	2413	1496	3909	200	202	342
VS 97/17	E8	75	100	2539	1496	4035	200	202	346,5
VS 97/18	E8	93	125	2665	1748	4413	200	202	429,5
VS 97/19	E8	93	125	2791	1748	4539	200	202	434,5
VS 97/20	E8	93	125	2917	1748	4665	200	202	439
VS 97/21	E8	93	125	3043	1748	4791	200	202	444
VS 97/22	E8	110	150	3169	1976	5145	200	202	512
VS 97/23	E8	110	150	3295	1976	5271	200	202	517

Dimensions

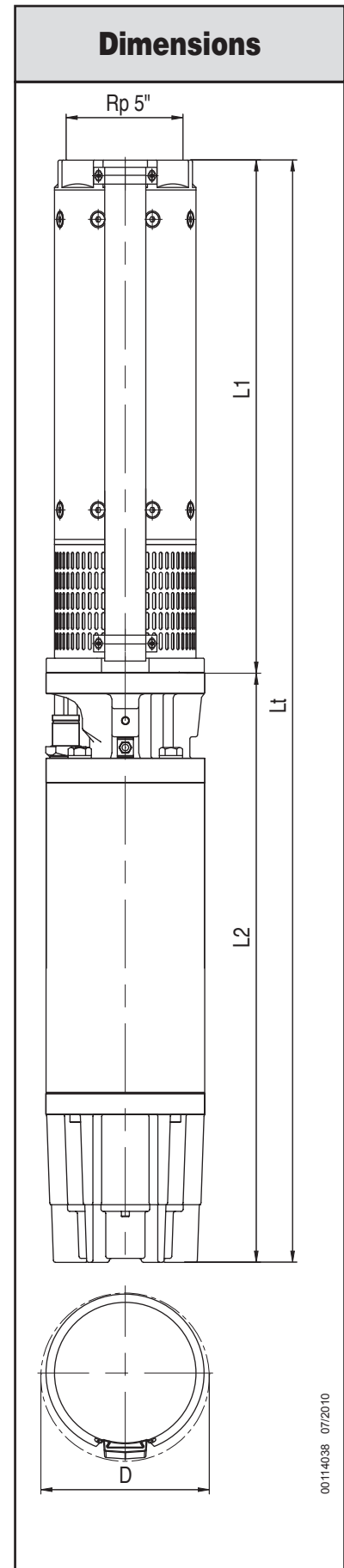

Pumps with Rewindable Motor

Pump model type	Motor			Dimensions					Weight Pump [Kg]
	Type	kW	HP	L1 [mm]	L2 [mm]	Lt [mm]	D		
							1 cable	2 cable	
VS 97/2	6RW	9,3	12,5	644	749	1393	188	194	84,5
VS 97/3	6RW	13	17,5	770	829	1599	188	194	97,5
VS 97/4	6RW	18,5	25	896	919	1815	188	194	111,5
VS 97/5	6RW	22	30	1022	1009	2031	188	194	125
VS 97/6	6RW	26	35	1148	1114	2262	188	194	141
VS 97/7	6RW	30	40	1274	1214	2488	188	194	156
VS 97/8	6RW	37	50	1400	1294	2694	188	194	168
VS 97/9	6RW	37	50	1526	1294	2820	188	194	173
VS 97/10	8RW	45	60	1657	1230	2887	197	199,5	228
VS 97/11	8RW	52	70	1783	1340	3123	197	199,5	256
VS 97/12	8RW	52	70	1909	1340	3249	197	199,5	261
VS 97/13	8RW	55	75	2035	1340	3375	197	199,5	266
VS 97/14	8RW	67	90	2161	1470	3631	197	199,5	290
VS 97/15	8RW	67	90	2287	1470	3757	197	199,5	295
VS 97/16	8RW	75	100	2413	1560	3973	197	199,5	317
VS 97/17	8RW	75	100	2539	1560	4099	197	199,5	321,5
VS 97/18	8RW	83	110	2665	1560	4225	197	199,5	358,5
VS 97/19	8RW	83	110	2791	1560	4351	197	199,5	363,5
VS 97/20	8RW	93	125	2917	1740	4657	197	199,5	368
VS 97/21	8RW	93	125	3043	1740	4783	197	199,5	373

00114038 07/2010

Performance curves 50Hz

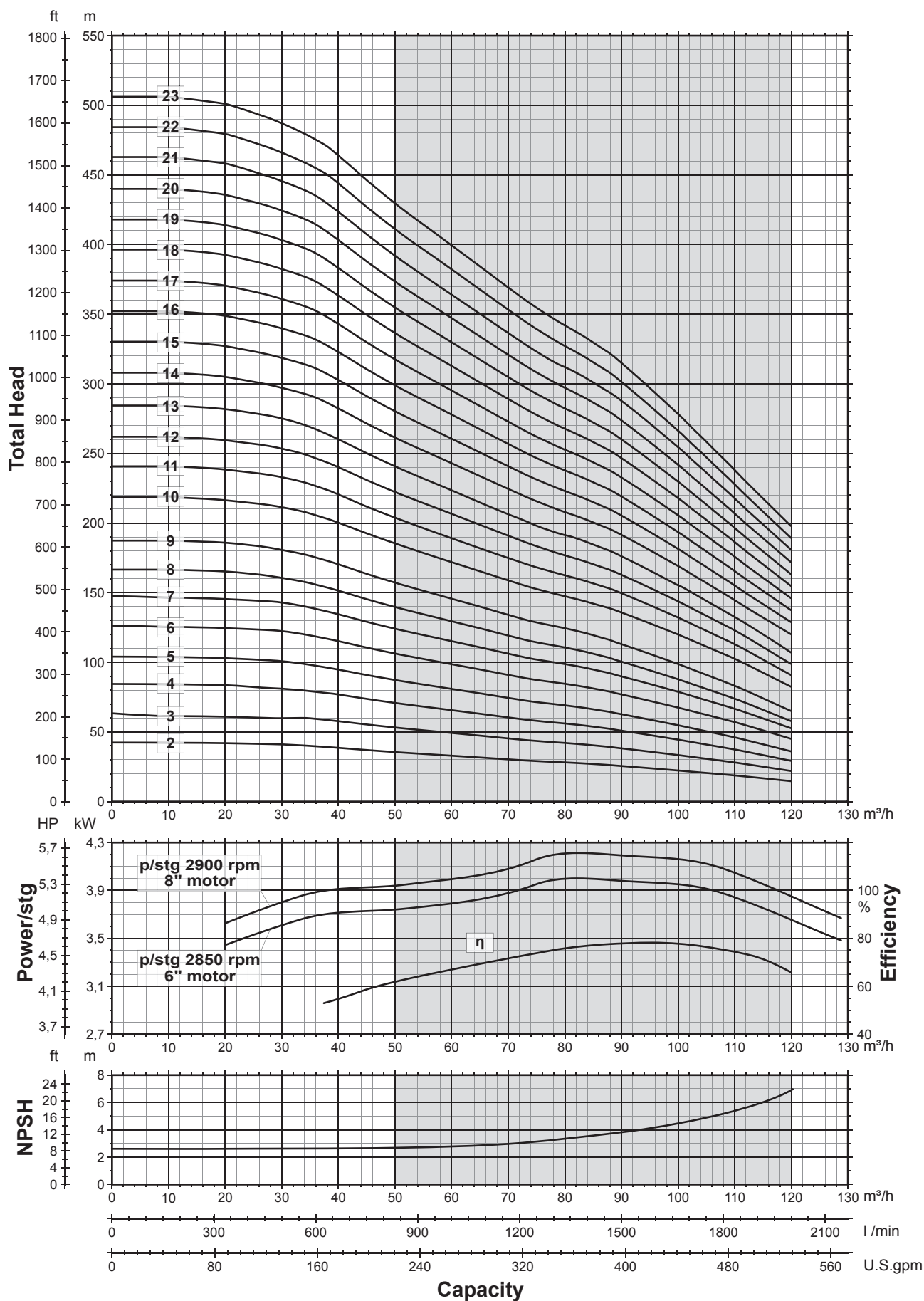

Section and List of Main Components

VS 78

VS 97

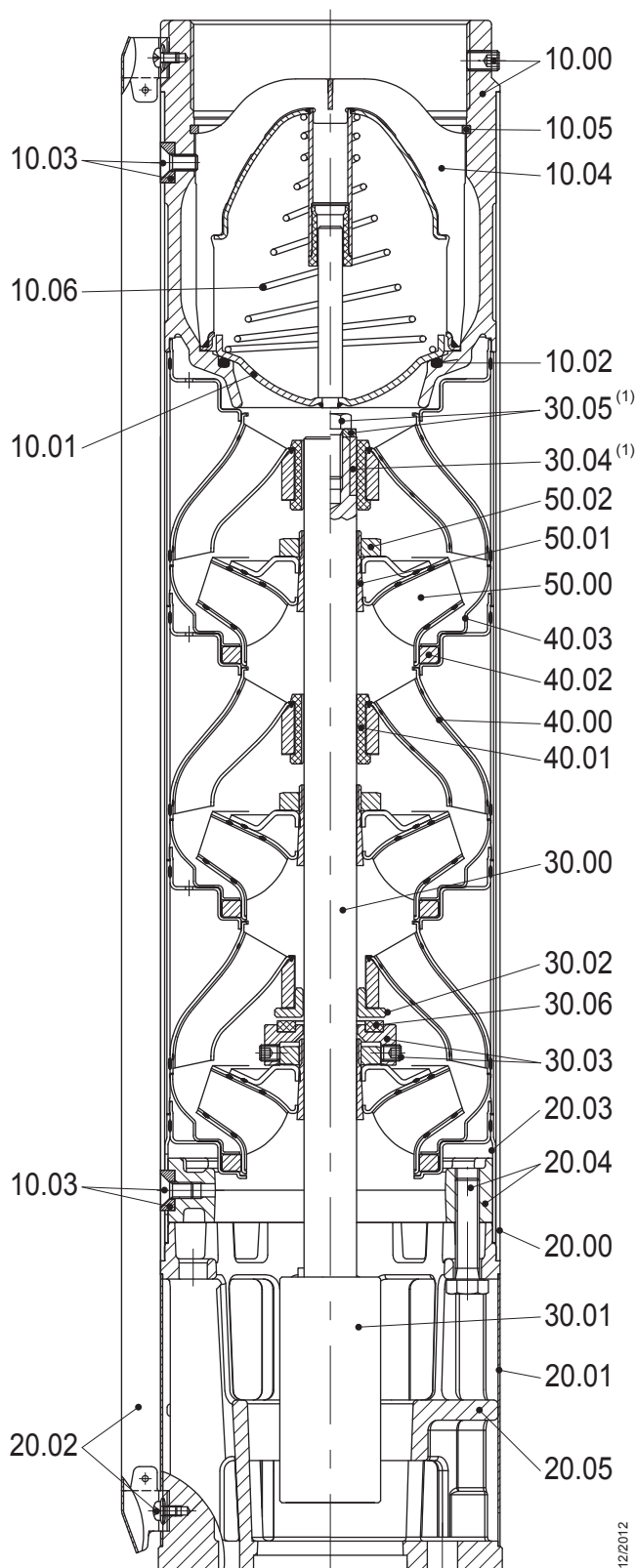

Ref. N.	Description
10 00	Discharge head
10 01	Valve
10 02	Sealing O-ring
10 03	Outer case locking nuts
10 04	Valve support
10 05	Seeger ring
10 06	Spring
20 00	Outer case
20 01	Suction strainer
20 02	Cable guard
20 03	Initial spacer
20 04	Flange
20 05	Motor adapter
30 00	Pump shaft
30 01	Coupling
30 02	Upper up-thrust washer
30 03	Lower up-thrust washer
30 04	Upper journal sleeve
30 05	Screw and washer
30 06	Up-thrust ring
40 00	Diffuser
40 01	Secondary bearing bush
40 02	Floating neck ring
40 03	Flange clamping neck ring
50 00	Impeller
50 01	Split cone
50 02	Split cone nut

1) only for types with more than 8 stages

00114037 12/2012

Motor Adapter VS 78 / 97

6" Motor Adapter

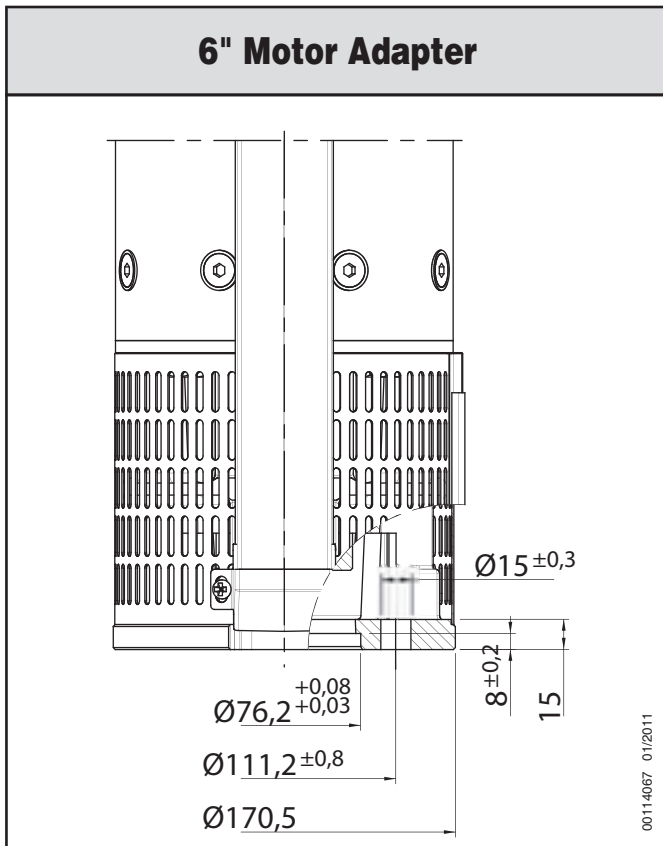

8" Motor Adapter

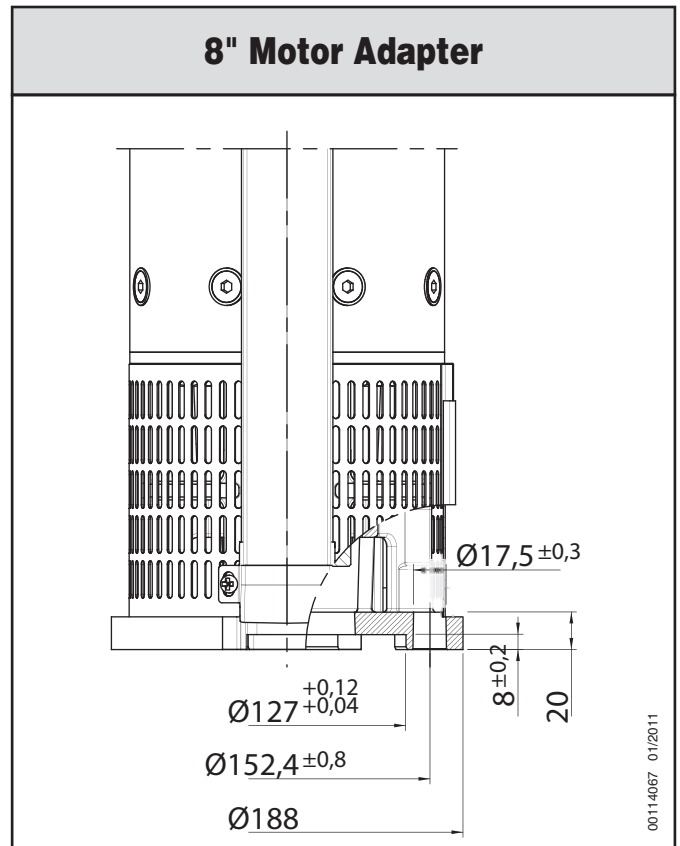

Submersible Motors Product Overview

4" Encapsulated Motors

4" Super Stainless 3 Phase

SUBMERSIBLE MOTORS

These 4" encapsulated three phase motors, manufactured in ISO 9001 certified facilities, are built for dependable operation in 4" diameter or larger water wells. The motor offer you a maintenance free long life submersible pump application.

The motor is filled with a special FES93 fluid, providing frost protection down to -40°C storage temperature. A special diaphragm ensures pressure compensation inside the motor.

FEATURES

- Hermetically sealed stator. Anti track, self healing stator resin prevents motor burn out
- High efficiency electrical design (low operation cost, cooler winding temperature)
- Removable "Water Bloc™" lead connector
- Cable material according to drinking water regulations (KTW approved)
- Water lubricated radial and thrust bearings
- All motors prefilled and 100% tested.
Non contaminating, FES93- filled design

SPECIFICATIONS

- 0,37 - 7,5kW
- 4" NEMA flange
- Degree of protection: IP68
- Insulation: Cl. B
- Rated ambient temp.: 30°C
- Cooling flow: Motors 2,2 kW and larger: min. 8 cm/s
- Starts/h: 20
- Mounting: vertical/horizontal
- Voltage tolerance: 380-415V/50Hz, 460V/60Hz; -10% / +6% U_N [380-415V = (380-10%) – (415+6%)]
- Motor protection: Select thermal overloads according to EN 60947-4-1, Trip time <10 s at 5 x I_N

AVAILABLE OPTIONS

- Motor cable VDE / KTW approved (1,5m; 2,5m; special lengths available)
- Motors with factory- installed lead in Single Packing
- Special voltages on request
- YΔ - start (pos. of cables 90°) in motors 316SS on request
- Motor complete in AISI 316SS with SiC seal



Performance table at ~2850 rpm

Three-Phase 4" Encapsulated Motors 400V

P_N	Thrust	n_N	I_N	I_A	η	$\cos \varphi$	T_N	T_A	L	Weight	
[kW]	[HP]	F [N]	[min ⁻¹]	[A]	[A]	[%]	[Nm]	[Nm]	[mm]	[kg]	
0,37	0,5	3000	2870	1,1	5,41	66	0,74	1,22	3,00	214,2	7,2
0,55	0,75	3000	2870	1,6	7,4	68	0,74	1,82	4,20	228,2	7,7
0,75	1	3000	2865	2,0	7,0	70	0,77	2,49	6,70	248,2	8,7
1,1	1,5	3000	2850	2,8	16,0	74	0,78	3,67	11,33	282,6	10,2
1,5	2	3000	2855	3,9	20,7	73	0,78	5,00	14,10	306,6	11,2
2,2	3	3000	2845	5,5	29,8	75	0,77	7,37	22,0	338,6	12,6
		6500*	2845	5,5	29,8	75	0,77	7,37	22,0	422,2	15,0
3,0	4	3000	2845	7,5	42,0	76	0,77	10,06	31,93	393,6	15,0
		6500*	2845	7,5	42,0	76	0,77	10,06	31,93	477,2	17,0
3,7	5	6500*	2840	9,0	52,3	78	0,78	12,5	41,5	520,2	19,1
4,0	5,5	6500*	2840	9,9	57,0	78	0,77	13,4	44,0	543,2	20,0
5,5	7,5	6500*	2865	12,6	77,2	79	0,81	18,3	56,5	652,5	26,6
7,5	10	6500*	2855	17,1	99,3	79	0,81	25,1	73,1	730,5	30,6

* High Thrust Version

Dimensions

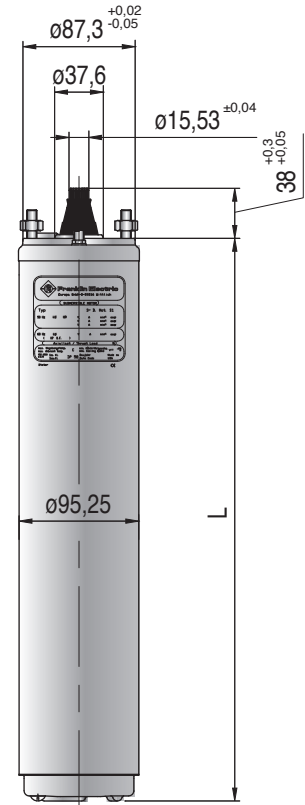

6" Encapsulated Motors

SUBMERSIBLE MOTORS

These 6" encapsulated motors, manufactured in ISO 9001 certified facilities, are built for dependable operation in 6" diameter or larger water wells.

Water lubricated thrust and radial bearings enable a maintenance free operation. A special diaphragm ensures pressure compensation inside the motor. The motor is filled with a special FES91 fluid, providing frost protection down to -15°C storage temperature.

The Sand fighter® SiC seal system is standard.

FEATURES

- Hermetically sealed stator, Anti track, self healing stator resin prevents motor burn out
- 37 and 45kW up to 50°C ambient temperature
- Removable "Water Bloc" lead connector
- Cable material according to drinking water regulations (KTW approved)
- „Sand fighter®" Motor with SiC-Mechanical Seal
- High efficiency electrical design for low operation cost
- All motors prefilled and 100% tested
Max. storage temperature -15°C – + 60°C
- Non contaminating FES91- filled design

SPECIFICATIONS

- 4 - 45 kW
- 6" NEMA flange
- Protection: IP 68
- Starts per hour: 20
- Installation: vertical/horizontal
- Standard voltage: 380-415V/50Hz, 460V/60Hz;
Voltage tolerance: +6% / -10% (Standard: 415 + 6% = 440V, 380 – 10% = 342V)
- Motor protection: Select thermal overloads according to DIN 60947-4-1, trip class 10 or 10A, trip time < 10 s at 5 x I_N
- Insulation: Class F
- YΔ - start (pos. of cables 90°)
- „Sand fighter®" Motor with SiC-Mechanical Seal
- Rated ambient temperature: 4 - 30 kW up to 30°C, 37 & 45 kW up to 50°C
- Cooling flow: min. 0,16 m/s
- Motor lead in 4m length (KTW approved)

AVAILABLE OPTIONS

- Other voltages
- Motors complete in 316 SS
- PT 100 temperature sensor (sold separately)
- Special Lead lengths up to 50m
- Built-in PTC temperature sensor
- Built-in SubMonitor Transmitter (standard for 37 & 45 kW)



Performance table at ~2850 rpm

Three-Phase 6" Encapsulated Motors 400V

P_N [kW]	Thrust [HP]	n_N F [N]	I_N [min ⁻¹]	I_A [A]	η [%]	$\cos \varphi$	T_N [Nm]	T_A [Nm]	L [mm]	Weight [kg]	
4	5,5	15500	2860	9,3	43	78	0,82	12,3	20,2	581,2	37,5
5,5	7,5	15500	2870	12,5	64	79	0,82	18,6	35,0	614,4	41,1
7,5	10	15500	2860	16,0	83	79	0,86	25,0	47,7	646,2	45,2
9,3	12,5	15500	2870	20,7	112	81	0,80	31,1	68,2	678,7	47,5
11	15	15500	2860	23,3	129	81	0,85	37,3	78,3	711,2	50,9
15	20	15500	2860	31,3	169	81	0,85	49,9	107,3	776,2	56,7
18,5	25	15500	2860	38,5	231	82	0,85	62,4	154,6	841,5	63,3
22	30	15500	2860	45,3	268	83	0,86	74,7	177,6	906,5	69,3
30	40	27500	2860	63,5	393	83	0,84	99,4	263,1	1036,6	83,9
37	50	27500	2875	79,0	411	81	0,85	123,6	280,8	1421,4	138
45	60	27500	2875	95,2	509	82	0,84	148,4	332,3	1573,8	152

Dimensions

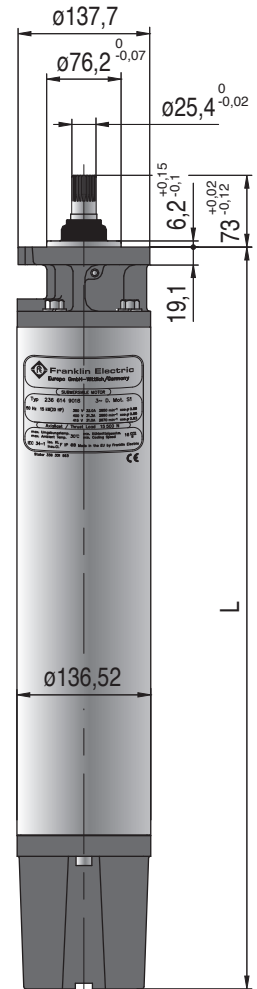

6" Rewindable Motors

SUBMERSIBLE MOTORS

These 6" rewindable motors, manufactured in ISO 9001 certified facilities, are built for dependable operation in 6" diameter or larger water wells. Water lubricated thrust and radial bearings enable a maintenance free operation. A special diaphragm ensures pressure compensation inside the motor. The motor is filled with a special FES93 fluid, providing frost protection down to -15°C storage temperature.

Fully standard Sand fighter® SiC seal system for sandy applications. For applications in aggressive media, motors made of 304 SS, 316 SS and 904L are available.

FEATURES

- new** ■ Fully Stainless Steel design for all Versions, Standard 304 SS
- new** ■ Truly rewindable (removable windings covers)
- new** ■ More operation safety margin (lower heat rise)
- new** ■ „Sand fighter®“ Motor with SiC-Shaft Seal as a standard
- new** ■ Motors ~17mm shorter and ~5kg decreased weight
- Cable material according to drinking water regulations (KTW approved)
- Sand slinger and mechanical seal for high performance in sand
- High efficiency electrical design for low operation cost
- All motors prefilled and 100% tested
- Max. storage temperature -15°C – +60°C
- Design for retrofittable PT100 sensor
- Approved Franklin Electric „Kingsbury Type“ thrust bearing
- Non contaminating FES93- filled design

SPECIFICATIONS

- 4 - 37 kW
- NEMA flange with Studs (M12)
- Protection: IP 68
- Starts per hour: max. 20
- Installation position: vertical / horizontal
- Motor Lead in 4m length (KTW approved)
- Standard voltage: 380-415V/50Hz, 460V/60Hz;
Voltage tolerance: +6% / -10% (Standard: 415 + 6% = 440V, 380 – 10% = 342V)
- Motor protection: Select thermal overloads according to EN 60947-4-1, trip class 10 or 10A, trip time < 10 s at 5 x I_N
- YΔ - start (pos. of cables 90°)
- Standard motor with PVC winding insulation (37kW in standard with PE2/PA insulation) for max. ambient temp. of 30°C with a min. cooling flow:

4 kW - 15 kW	v = 0,2 m/s
18,5 kW - 37 kW	v = 0,5 m/s

AVAILABLE OPTIONS

- Other voltages
- Motors in complete 316 SS and 904 L
- Motors up to 30 kW with PE2/PA winding insulation for max. ambient temp. of 50°C at the same cooling conditions as standard (37 kW max. 45°C)
- PT 100 temperature sensor (sold separately)
- Lead in different lengths up to 50m



Performance table at ~2850 rpm

Three-Phase 6" Rewindable Motors 400V

P_N [kW]	Thrust [HP]	n_N F [N]	I_N [min ⁻¹]	I_A [A]	η [%]	$\cos \varphi$	T_N [Nm]	T_A [Nm]	L [mm]	Weight [kg]	
4	5,5	15500	2930	10,6	51	76	0,73	13,1	17,3	682	43
5,5	7,5	15500	2890	13,3	51	76	0,81	18,2	17,3	682	43
7,5	10	15500	2880	17,7	63	77	0,82	24,8	21,5	702	45
9,3	12,5	15500	2870	21,4	78	78	0,82	31,0	29,0	732	48
11	15	15500	2880	25,2	98	79	0,83	36,4	35,3	762	51
13	17,5	15500	2900	29,6	125	80	0,81	42,8	50,3	812	56
15	20	15500	2890	33,1	148	81	0,83	49,4	60,4	857	61
18,5	25	15500	2880	42,0	182	81	0,80	61,2	84,3	902	65
22	30	15500	2900	49,0	231	82	0,80	72,5	102,2	992	74
26	35	15500	2900	56,7	284	83	0,83	85,6	134,7	1097	85
30	40	27500	2910	66,4	347	83	0,80	98,4	151,0	1197	95
37	50	27500	2900	81,9	433	83	0,80	121,6	215,8	1277	102

Dimensions

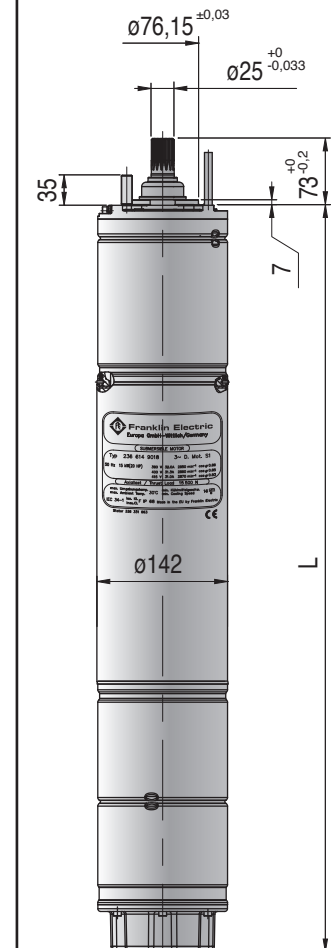

8" Encapsulated Motors

SUBMERSIBLE MOTORS

These 8" encapsulated motors, manufactured in ISO 9001 certified facilities, are built for dependable operation in 8" diameter or larger water wells.

It is fitted with water lubricated radial and thrust bearings for maintenance-free operation. A special diaphragm ensures pressure compensation inside the motor. The motor is filled with a special FES91 fluid, providing frost protection down to -15°C storage temperature.

The Sand fighter® SiC seal system is the option for sandy applications.

FEATURES

- Hermetically sealed stator, Anti track, self healing stator resin prevents motor burn out
- Removable "Water Bloc" lead connector
- Cable material according to drinking water regulations (KTW approved)
- Sand slinger and Mechanical seal for high performance in sand
- High efficiency electrical design for low operation cost
- All motors prefilled and 100% tested
Max. storage temperature -15°C – + 60°C
- Non contaminating FES91- filled design

SPECIFICATIONS

- 30 - 150 kW
- 8" NEMA flange
- Protection: IP 68
- Starts per hour: 20
- Installation: vertical/horizontal
- Standard voltage: 380 - 415V/50Hz, 460V/60Hz
Voltage tolerance: +6% / -10%
(Standard: $415 + 6\% = 440V$, $380 - 10\% = 342V$)
- Motor protection: Select thermal overloads according to DIN 60947-4-1, trip class 10 or 10A, trip time < 10 s at $5 \times I_N$
- Insulation: Class F
- YΔ - start (pos. of cables 90°)
- Rated ambient temperature: 30°C
- Cooling flow: min. 0,16 m/s
- Built-in Subtrol Heat Sensor
- Motor lead in 8 m length (KTW approved)

AVAILABLE OPTIONS

- Other voltages
- Motors complete in 316 SS
- PT 100 temperature sensor (sold separately)
- „Sand fighter®" Motor with SiC- Mechanical seal



Performance table at ~2900 rpm

Three-Phase 8" Encapsulated Motors 400V

P_N	Thrust	n_N	I_N	I_A	η	$\cos \phi$	T_N	T_A	L	Weight	
[kW]	[HP]	F [N]	[min ⁻¹]	[A]	[A]	[%]	[Nm]	[Nm]	[mm]	[kg]	
30	40	45000	2900	61	418	86	0,84	97	255	909	116
37	50	45000	2920	74	534	87	0,86	121	295	986	131
45	60	45000	2920	89	645	87	0,85	145	395	1062	145
55	75	45000	2920	108	862	88	0,87	182	563	1204	175
75	100	45000	2925	145	1157	87	0,87	242	561	1395	213
93	125	45000	2930	190	1332	87	0,83	302	567	1747	291
110	150	45000	2930	222	1597	88	0,84	363	769	1975.6	334
130	175	45000	2920	252	1738	88	0,87	424	927	2178.8	380
150	200	45000	2920	284	1858	88	0,88	485	1034	2407.4	429

Dimensions

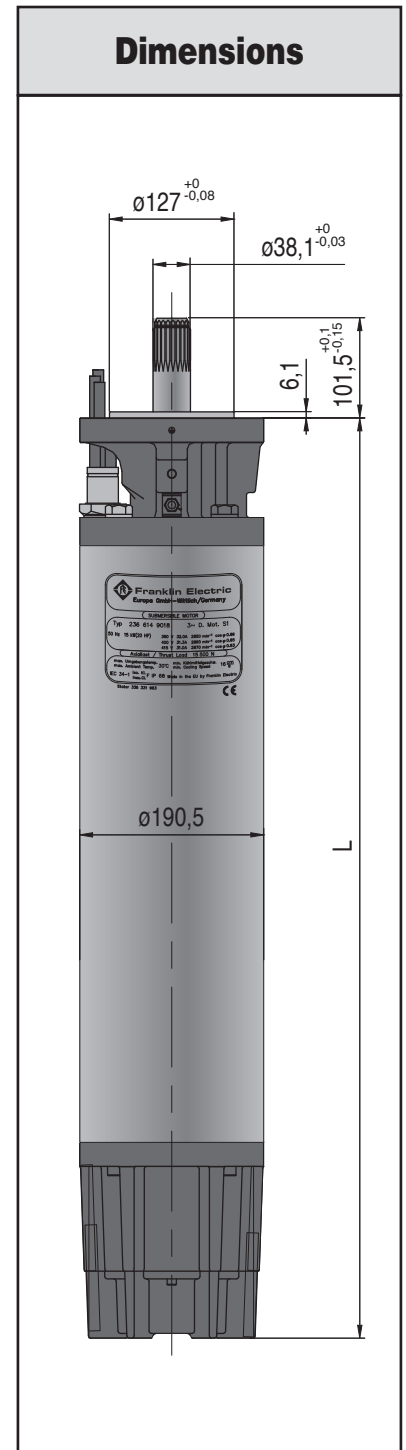

8" Rewindable Motors

SUBMERSIBLE MOTORS

These 8" rewindable motors, manufactured in ISO 9001 certified facilities, are built for dependable operation in 8" diameter or larger water wells. It is fitted with water lubricated radial and thrust bearings for maintenance-free operation. The motor is filled with a special FES93 fluid, providing frost protection down to -15°C storage temperature.

A special diaphragm ensures pressure compensation inside the motor. The Sand fighter® SiC seal system is standard. For applications in aggressive media, motors made of 316SS and 904L are available.

FEATURES

- Easy to assemble with double flange
- Cable material according to drinking water regulations (KTW approved)
- Sand fighter® SiC seal system for high performance in sand
- High efficiency electrical design for low operation cost
- All motors prefilled and 100% tested
- Max. storage temperature -15°C – +60°C
- Design for retrofitable PT100 sensor
- Non contaminating FES93- filled design

SPECIFICATIONS

- 30 - 93 kW
- 8" NEMA flange
- Protection: IP 68
- Starts per hour: max. 20
- Installation position: vertical / horizontal
- (93 kW motors may not be installed horizontally)
- Motor Lead in 6 m length (KTW approved)
- Standard voltage: 380-415V/50Hz, 460V/60Hz;
Voltage tolerance: +6% / -10% (Standard: 415 + 6% = 440V, 380 – 10% = 342V)
- Motor protection: Select thermal overloads according to EN 60947-4-1, trip class 10 or 10A, trip time < 10 s at $5 \times I_N$
- YΔ - start (pos. of cables 90°)
- Standard motor with PVC winding insulation
- For max. ambient temp. of 30°C with a min. cooling flow:

30 kW - 52 kW	v = 0,2 m/s
55 kW - 93 kW	v = 0,5 m/s

AVAILABLE OPTIONS

- Other voltages
- Motors in complete 316 SS and 904 L
- YΔ - start (pos. of cables 90°)
- PE2/PA winding insulation for max. ambient temp. of 50°C at the same cooling conditions as standard
- PT 100 temperature sensor (sold separately)
- Lead in different lengths up to 50m



Performance table at ~2900 rpm

Three-Phase 8" Rewindable Motors 400V

P_N [kW]	Thrust [HP]	F [N]	n_N [min ⁻¹]	I_N [A]	I_A [A]	η [%]	$\cos \varphi$	T_N [Nm]	T_A [Nm]	L [mm]	Weight [kg]
30	40	45 000	2900	60	318	84	0,89	99	141	1140	140
37	50	45 000	2900	76	400	84	0,86	122	176	1140	140
45	60	45 000	2910	90	520	86	0,86	148	241	1230	156
52	70	45 000	2910	103	608	86	0,87	175	318	1340	179
55	75	45 000	2915	110	660	86	0,86	181	340	1340	179
60	80	45 000	2910	116	725	87	0,88	197	357	1470	198
67	90	45 000	2910	133	797	87	0,86	220	359	1470	198
75	100	45 000	2910	148	942	87	0,87	246	472	1560	215
83	110	45 000	2920	160	1077	88	0,88	273	544	1560	247
93	125	45 000	2920	183	1276	88	0,86	305	626	1740	247

Dimensions

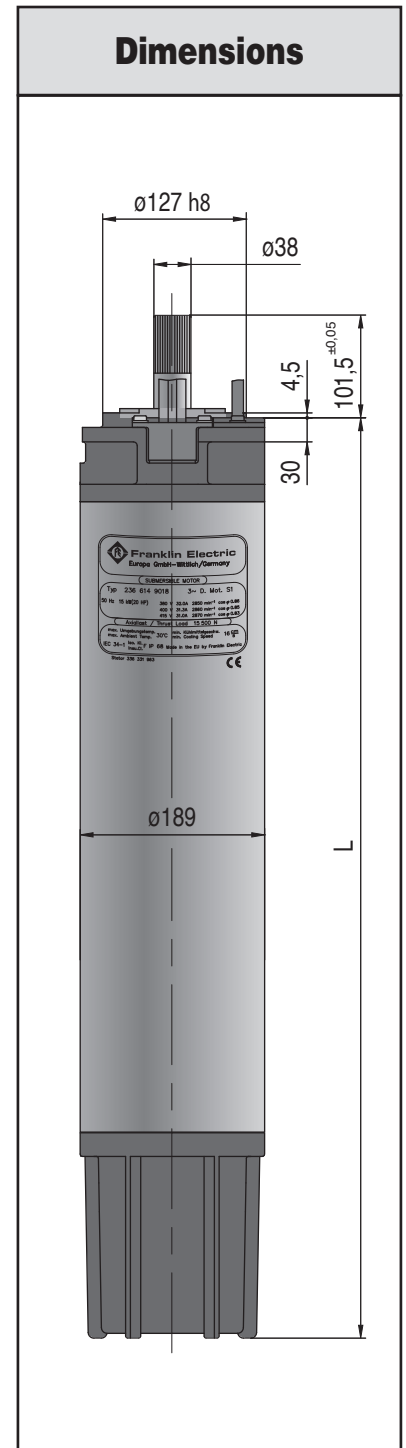

Motor Control

SUBMONITOR MOTOR PROTECTION

The SubMonitor is designed to protect 3-phase pumps with horsepower ratings between 3 and 200 Hp. Current, voltage and motor temperature are monitored using three integrated current transformers. A digital display provides current and voltage readings for all three legs and allows the user to set up the SubMonitor quickly and easily. The SubMonitor is the latest innovation in 3-phase pump protection from Franklin Electric. Using state-of-the-art technology, the SubMonitor provides the ultimate protection for a pump and motor. There is simply no better way to protect a large 3-phase submersible pump investment than with a SubMonitor. It's the protection device that can sense overheating straight from the motor windings! And it is made by the world leader in submersible motors - Franklin Electric.



FEATURES

- Quick setup to monitor a motor, simply enter the Line Frequency (Hz), Line Voltage (volts), and Motor Service Factor Amp rating
- Digital display indicates voltage and current on all three legs at the same time, and fault messages are in easily understandable text
- Monitors - Under/Overload; Under/Overtorque; Current Unbalance; Overheated Motor (Subtrol Equipped); False Start (Chattering); Phase Reversal
- For motors with service factor amp ratings between 3 and 359 amps
- One unit covers the entire range from 190 to 600 Volts
- No need to make additional turns around the CT or add external CTs
- Password Protection Option
- DIN Rail Mounting Option
- Stores fault, setting changes, and pump run-time, that can be accessed through the display
- Detachable NEMA 3R display unit can be mounted on panel door
- UL 508 Listed

Model number

Premium Package	586 000 5100
Input Voltage	190 – 600 VAC
Frequency	60/50 Hz
Motor Service Factor Amps	3 to 359 Amps
Maximum Conductor Size Through Sensors	
Max. Diameter	0.920 in. (23 mm)
Trip Response	
Motor, Under / Overload, Under / Overtorque, Overheat Unbalance	3 seconds
Control Circuit Rating	1.5 Amp AC, up to 600 volts
Signal Circuit Rating	1 Amp AC, up to 250 volts (Incandescent: 100 watts max.)
Wiring Terminals	
Wire Gauge	#12 to #18 AWG
Tighten to	4.5 in-lbs
Weight (SubMonitor)	3.3 lbs/7,3 kg
Carton Size (Std. Unit)	7,75 in x 11,5 in x 6,75 in (19,7 cm x 29,2 cm x 17,1 cm)
Shipping Weight (Std. Unit)	3.5 Lbs./7.5 kg

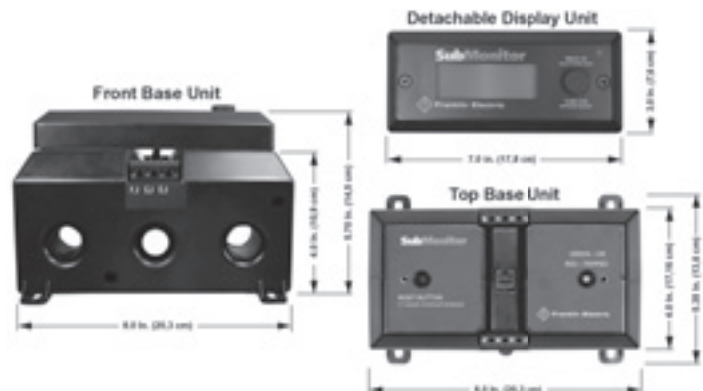

Motor Control

SubStartSC® Single phase Submersible Motor Starter

The SubStartSC® range covers all PSC motors from 0.25kW to 2.2kW for all voltages. Ergonomic design, attention to detail and unique features make the SubStartSC® motor starter range your first choice when considering submersible motor protection. In conjunction with Franklin Electric submersible motors you now have an tangible water system advantage resulting in ease of installation and reliable protection.

FEATURES

- Attention to detail – every aspect engineered for the application
- The complete package – The device is 100% compatible with the motor characteristics
- All in one name – Reliability backed by the leader in submersible motors



Ergonomically designed

Mounting	Easy wall mounting without destroying the protection rating of the enclosure.
Wiring	Sufficient space is provided for ease of wiring.
Enclosure	
Protection	IP54
Material	IN
Components	
ON/OFF switch	Illuminated integral ON/OFF switch for ease of power
Circuit breaker	Thermal circuit breaker for protection of the motor.
Capacitor	High quality motor run capacitor for long life
Terminal board	Terminal board suitable for ease of reliable connections
Cable glands	Cable glands to ensure IP54 rating

Technical Specifications

Mechanical	
Protection level	IP54
External dimensions	168 x 142 x 85mm
Weight	0,6 - 1,0 kg
Mounting	Wall mounting (mounting hardware provided)
Temperature	-5°C - +40°C
Humidity	50% at 55°C (without condensation)
Electrical	
Voltage	220 - 240V; - 1 / +10 %; 50Hz single phase
Current	16 A
Power	0,25 - 2,2 kW

Standards

IEC 60439-1

Submersible Motor Starter Specifications

Part Number ¹	Type ²	Motor rating (kW)	Nominal Current ³ (A)	Maximal expected current ⁴ (A)	Capacitor (µF) 450V ac
284 623 3510	SS025SC	0,25	2,5	8,4	12,5
284 624 3510	SS037SC	0,37	3,4	11,2	16
284 625 3510	SS055SC	0,55	4,3	16,1	20
284 626 3510	SS075SC	0,75	5,8	21,1	35
284 627 3510	SS110SC	1,10	8,6	31,5	40
284 628 3510	SS150SC	1,50	10,6	35,4	50
284 629 3510	SS220SC	2,20	16,0	54,2	70

NOTES:

1. Can be used with both 220-230V and 230-240V PSC motor ranges.
2. Type indicates motor power rating and motor type.
3. Nominal supply current at nominal voltage
4. Motor starting current under nominal conditions

Dimensions

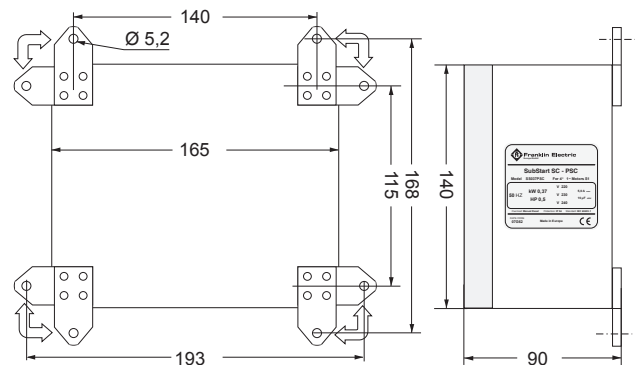

Termination Kit 4"

This proven, sturdy solution is your choice of cable joining in temporary pump applications or when re-usage if the drop cable is desired. Furthermore, the flexibility and safety it provides for under field service conditions makes it the preferred choice over conventional, not breakable splicing kits.



Double Plug Lead for Termination Kit

- 2-wire / 3-wire
- 1,5m / 2,5m Lead length
- with / without Strain relief
- Max. current 16 Apms.
- KTW approved



Corrosion Protection 4"

APPLICATION

The sacrificial anode attaches to the bottom end bell of Franklin Electric 4" Super Stainless submersible motors. Since cast iron is more chemically active than the metals that make up the motor and pump, it is the cast iron that reacts to the corrosive elements in the water. This results in longer motor and pump life in aggressive/corrosive water conditions.

LT

HT



Motor Filling Kit

This kit offers all tools for control the level of the engine filling liquid and to fill up if necessary!



6" Permanent Star Plug

APPLICATION

For some applications it may be necessary to permanently run a star-delta submersible motor in star connection. This may be achieved by using the PERMANENT-STAR-PLUG. This connector short - circuits all three pins in one of the two motor sockets and is designed to replace one lead.



Surge Arrestor

APPLICATION

These surge arrestors or their equivalents are highly recommended for protecting submersible motors from a variety of commonly occurring high voltage spikes which can damage the motor insulation system and cause motor winding failure. These arrestors will not, as is true of any surge protection equipment, protect the motor from a direct lightning strike.



PT100 for 6" and 8" Encapsulated Motors

APPLICATION

The PT100 is a precision platinum wire resistor that is specified occasionally as a temperature input for process control equipment. A jacketed control lead must be run from the PT100 lead to the above-ground equipment. The above-ground equipment is not available from Franklin Electric and is typically part of a custom panel or data acquisition system.

PT100 sensor retrofit kits from Franklin Electric come with complete instructions and allow for easy field installation.



PT100 Rewindable Motors

APPLICATION

- Fitted into the upper end bell flange, all end bells 6", 8" and 10" Rewindable are prepared for installation PT 100
- Measures the temperature of the filling liquid
- Conductor with a resistance proportional to the temperature
- Allows monitoring the temperature continuously

The above-ground equipment is not available from Franklin Electric and is typically part of a custom panel or data acquisition system. PT100 sensor retrofit kits from Franklin Electric come with complete instructions and allow for easy field installation.



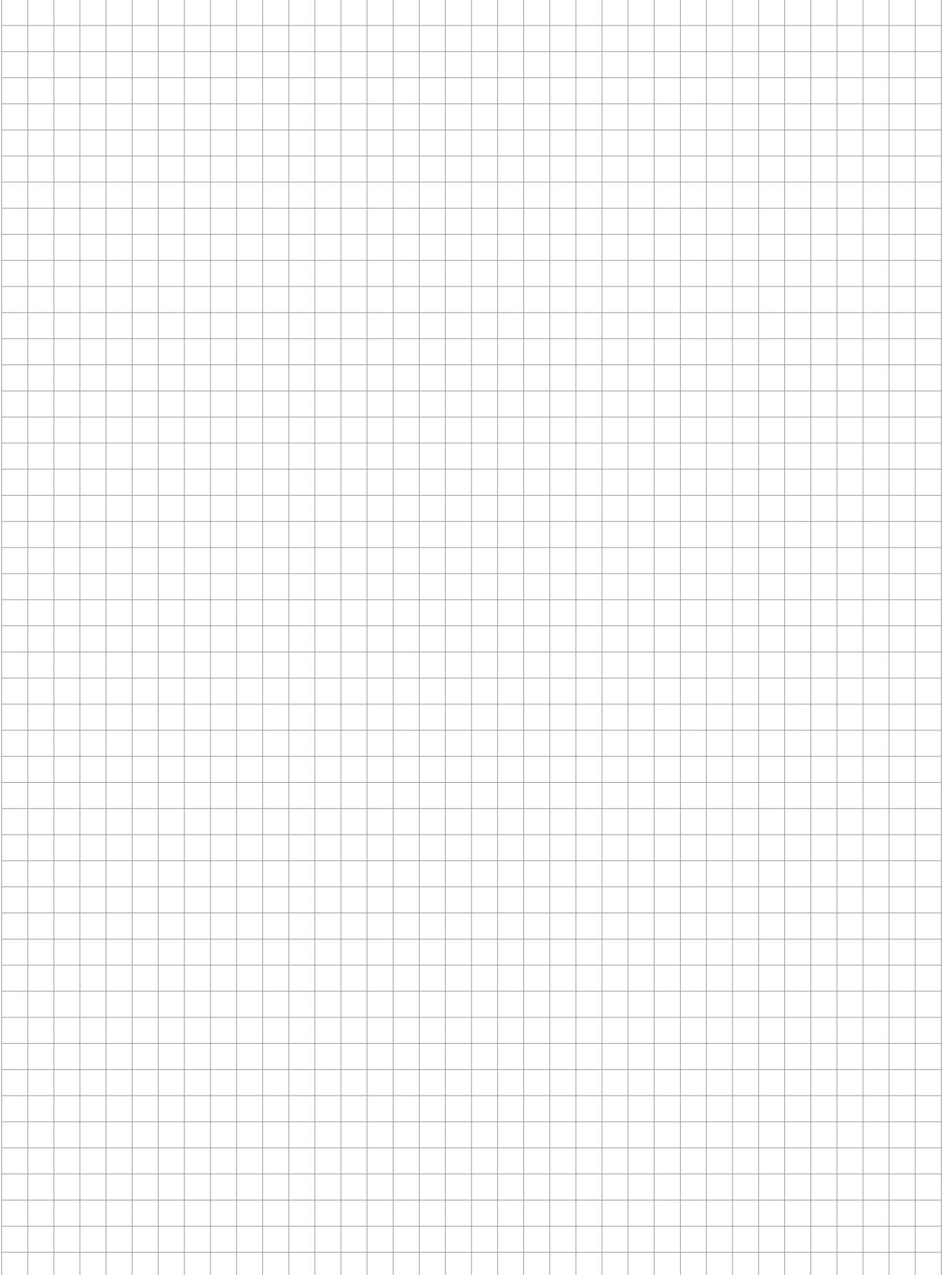

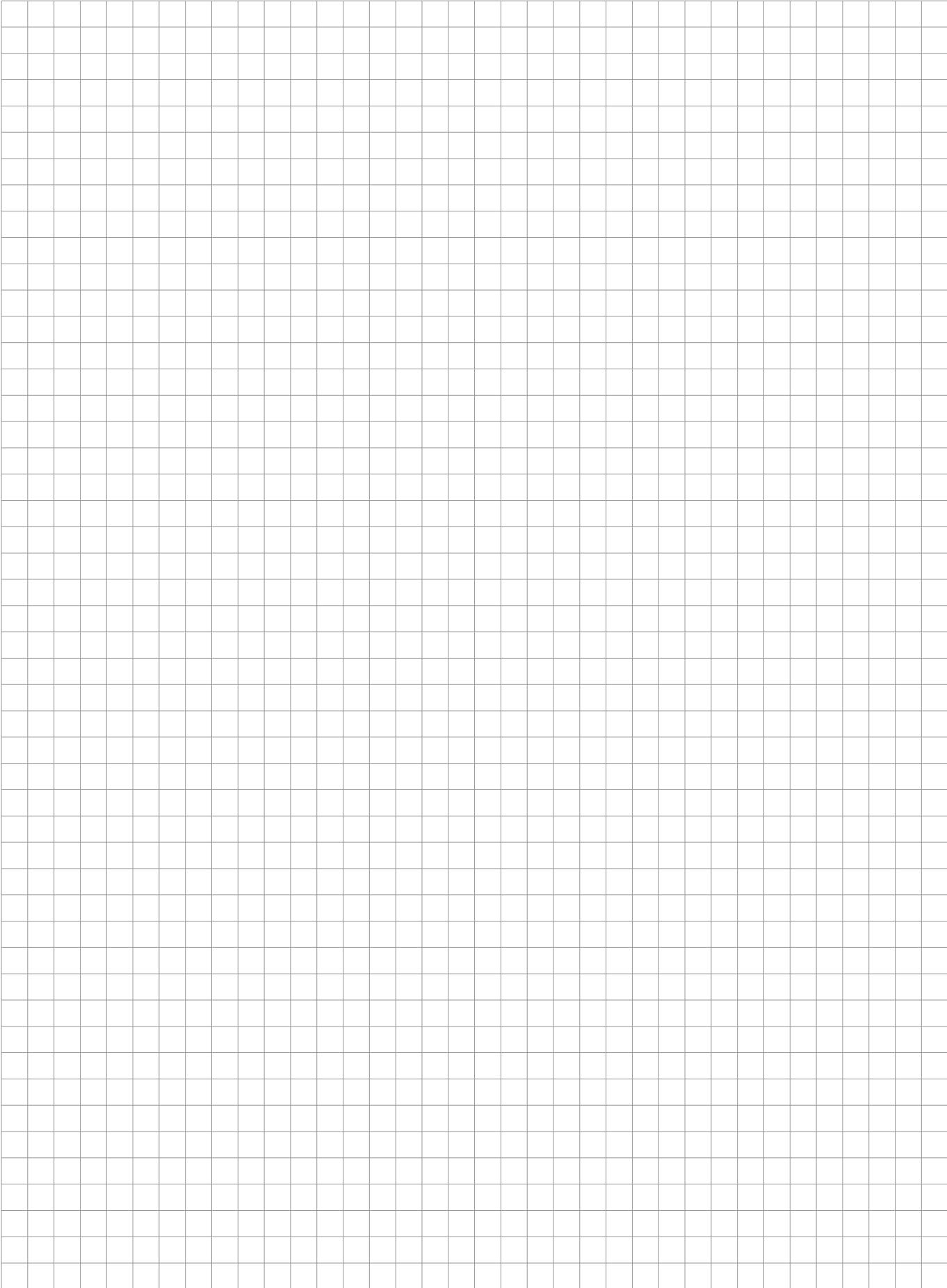

Franklin Electric S.r.l.
via Asolo, 7
36031 Dueville (Vicenza) - Italy
Tel. +39 0444 361114
Fax +39 0444 365247
P.IVA e C.F. 00558130241
e-mail: sales.it@fele.com
www.etechpumps.com

*Single member - Company subject to the control
and coordination of Franklin Electric Co., Inc.*